



Mechanical Diaphragm Metering Pump

Pulsafeeder Expertise

Since 1936, Pulsafeeder has been the global leader in fluids handling technology and innovation in chemical dosing. Pulsafeeder has built a foundation of success with thousands of installations in fluid handling applications. Our extensive product breadth enables us to provide the convenience and efficiency of single-source solutions across various industries.

OMNI Series Pumps

The OMNI series is designed to be an economical, compact, rugged, simple, and reliable diaphragm metering pump. It features an industrial design to work in just about any application. OMNI series pumps are an outstanding choice for the customer looking for a simple and compact diaphragm metering pump. These reliable metering pumps are designed to perform in the widest range of chemical dosing applications.

Product Specifications

- Flows to 3600 l/h (951 GPH) at 60 Hz
- Pressures to 10.3 Bar (150 PSI)
- Accuracy +/- 2% of flow
- Temperatures to 65°C (150°F)
- Viscosity up to 1000 CPS
- Maximum 3m (10ft) NPSH
- Maximum Suction Pressure 5 PSI or 0.4 bar less than design pressure

Materials of Construction

- Head materials- PVDF, 316SS, or PP
- Ball Valves - Ceramic or 316SS
- Diaphragm - PTFE faced Hypalon on DC 2-6, solid PTFE on DC7

Typical Applications

- Acids
- Caustics
- Polymers
- Bleaches
- pH Control
- Solvents
- Dyes/Inks
- Catalysts
- Cleaning agents
- And many more

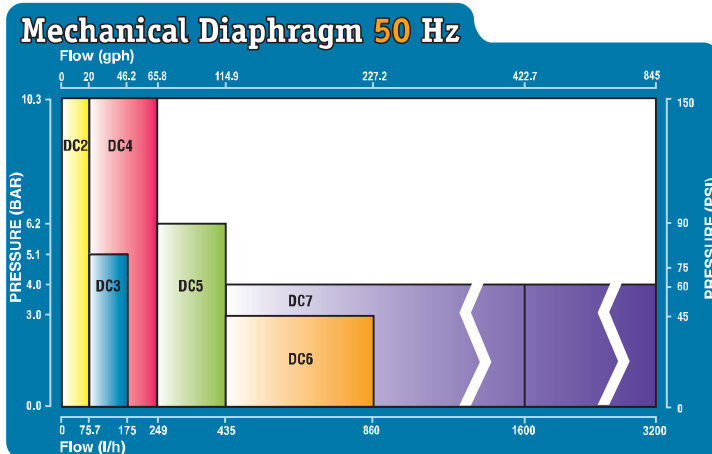

OMNI Performance 50Hz

Model	50 Hz Flow LPH (GPH)		Pressure		SPM@ 50 Hz		Power	
	1450 RPM	940 RPM	Bar	PSI	1450 (940) RPM	KW	HP	
DC 2A	22 (5.8)	14 (3.8)	10.3	150	37 (24)	0.18	0.25	
DC 2B	44(11.6)	28(7.5)	10.3	150	73 (47)	0.18	0.25	
DC 2C	75.7(20)	49(13.0)	10.3	150	125 (81)	0.18	0.25	
DC 3B	102 (26.9)	66 (17.4)	5.1	75	73 (47)	0.18	0.25	
DC 3C	175 (46.2)	113(30)	5.1	75	125 (81)	0.18	0.25	
DC 4B	128 (33.8)	83 (21.9)	10.3	150	98 (64)	0.37	0.5	
DC 4C	195 (51.5)	126 (33.4)	10.3	150	146 (95)	0.37	0.5	
DC 4D	249 (65.8)	161 (42.7)	10.3	150	186 (121)	0.37	0.5	
DC 5C	330 (87.2)	214 (56.5)	6.2	90	146 (95)	0.37	0.5	
DC 5D	435 (114.9)	282(74.5)	6.2	90	186 (121)	0.37	0.5	
DC 6C	690 (182.3)	447 (118.2)	3	45	146 (95)	0.37	0.5	
DC 6D	860 (227.2)	558 (147.3)	3	45	186 (121)	0.37	0.5	
DC 7C	1300 (343)	843(222.6)	4	60	146 (95)	1.1	1.5	
DC 7D	1600 (423)	1037 (274.0)	4	60	186 (121)	1.1	1.5	
DC 7J Dpx	2600 (687)	1686 (445.3)	4	60	146 (95)	1.1	1.5	
DC 7K Dpx	3200 (845)	2074 (548.0)	4	60	186 (121)	1.1	1.5	

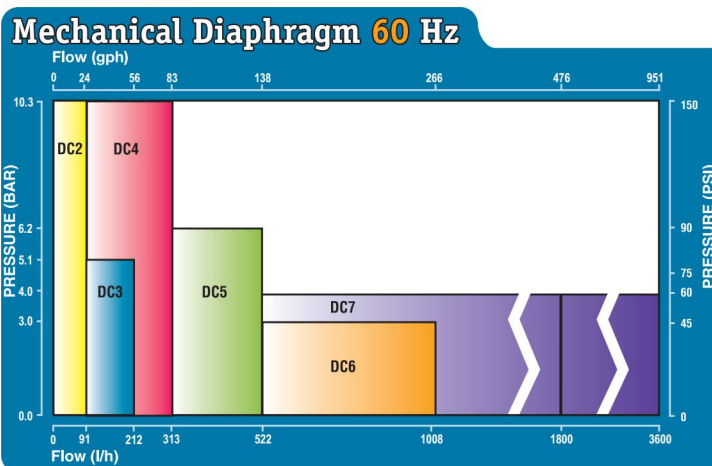

OMNI Performance 60Hz

Model	60 Hz Flow LPH (GPH)		Pressure		SPM@ 50 Hz		Power	
	1725 RPM	1140 RPM	Bar	PSI	1725 (1140) RPM	KW	HP	
DC 2A	26.5 (7)	17.5 (4.6)	10.3	150	44 (29)	0.18	0.25	
DC 2B	53 (14)	35 (9.3)	10.3	150	88 (58)	0.18	0.25	
DC 2C	91 (24)	60 (16)	10.3	150	150 (99)	0.18	0.25	
DC 3B	123 (32.4)	81 (21.4)	5.1	75	88 (58)	0.18	0.25	
DC 3C	212 (56)	140 (37)	5.1	75	150 (99)	0.18	0.25	
DC 4B	159 (42)	105 (27.7)	10.3	150	117 (77)	0.37	0.5	
DC 4C	246 (65)	163 (43)	10.3	150	175 (116)	0.37	0.5	
DC 4D	313 (83)	207 (55)	10.3	150	223 (147)	0.37	0.5	
DC 5C	409 (108)	270 (71)	6.2	90	175 (116)	0.37	0.5	
DC 5D	522 (138)	345 (91)	6.2	90	223 (147)	0.37	0.5	
DC 6C	804 (212)	531 (140)	3	45	175 (116)	0.37	0.5	
DC 6D	1008 (266)	666 (176)	3	45	223 (147)	0.37	0.5	
DC 7C	1440 (380)	952 (251)	4	60	175 (116)	1.1	1.5	
DC 7D	1800 (476)	1190 (314)	4	60	223 (147)	1.1	1.5	
DC 7J Dpx	2880 (761)	1903 (503)	4	60	175 (116)	1.1	1.5	
DC 7K Dpx	3600 (951)	2379 (638)	4	60	223 (147)	1.1	1.5	

Mechanical Diaphragm Technology

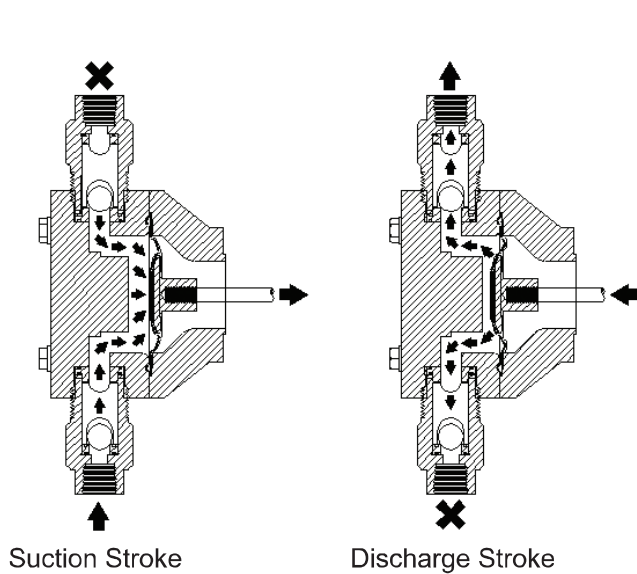

Diaphragm is mechanically attached to the reciprocating piston. The reciprocating diaphragm displaces controlled volume of process fluid through the suction and discharge valve mechanism.

Benefits:

- Eliminates hydraulic fluid
- Simplifies commissioning and maintenance
- Minimizes power requirements
- Economical pumping solutions

Completely non-vented Gearbox Design (DC7) prevents condensation and ingress of water and other contaminants. This provides exceptional durability and protection from the most extreme environments.

Rugged Power Transmission Benefits:

- Heavy duty worm gear is hardened and polished steel for DC7
- DC2-DC6 worm gear is constructed of durable long life Bronze
- Double shielded greased for life bearings reduce your maintenance

OMNI Configurations

OMNI Series pumps are available in several configurations to meet any pumping challenge. Shown below: DC3, DC5, DC7 and DC7 Duplex.



Features & Benefits



Easy to Install, Rugged Construction

- Simple, intuitive design is easy to operate and maintain
- Oil free, greased for life bearing with no more oil to buy or change (DC 2-6, DC7 has oil bath)
- Compact and lightweight
- Designed to withstand both indoor or outdoor rigors (when protected from precipitation and direct sunlight)
- Fan cooled motor design



Patented Stroke Adjustment Mechanism (DC7 only)

- Metering accuracy to +/-2% of flow
- Provides full motion operation
- Easy to read adjustment knob



Manual Stroke Adjustment Mechanism (DC2-6 only)

- Simple, click in place manual adjustment
- Lock mechanism to assure desired setting is maintained
- Turndown capacity adjustable up to 1000:1 with MPC controls



Patented Quick Change Check Valve System (DC7 only)

- Unique ball valve design is easy to access and very accurate
- Stands up to wide range of acids, caustics and solvents
- Completely inline accessible. No need to remove piping to service
- Includes PVDF, PP & 316 SS materials



Cartridge Check Valves (DC2-6 only)

- Guided ball check system reduces back flow and enhances priming characteristics
- Simple o-ring seals provide for reliable leak free performance and easy replacement



Controller Ready

- MPC controller option for DC 2-6
- Handheld remote controller on pump or wall mounted
- Display in LPH or GPH

OMNI Components

DC2-6

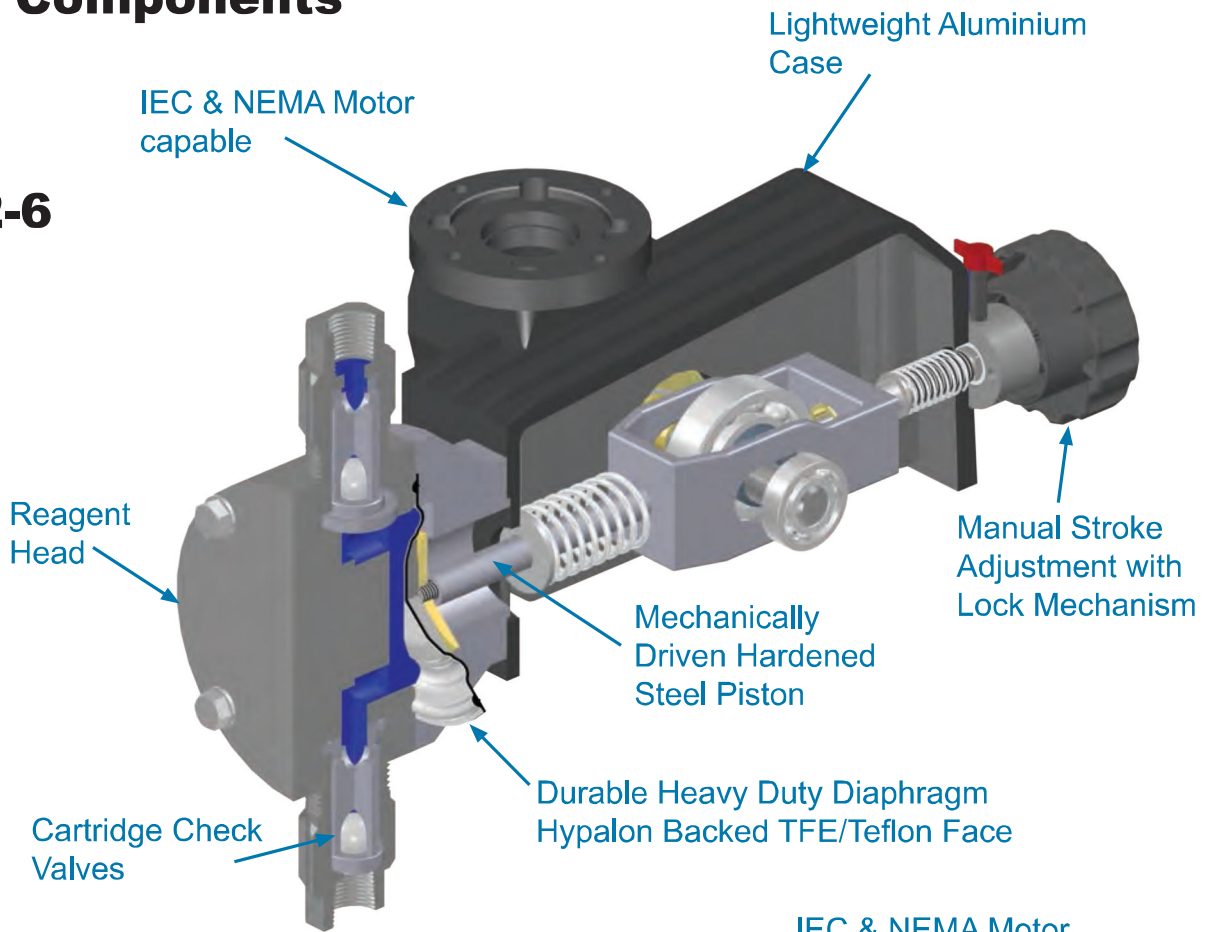

DC7

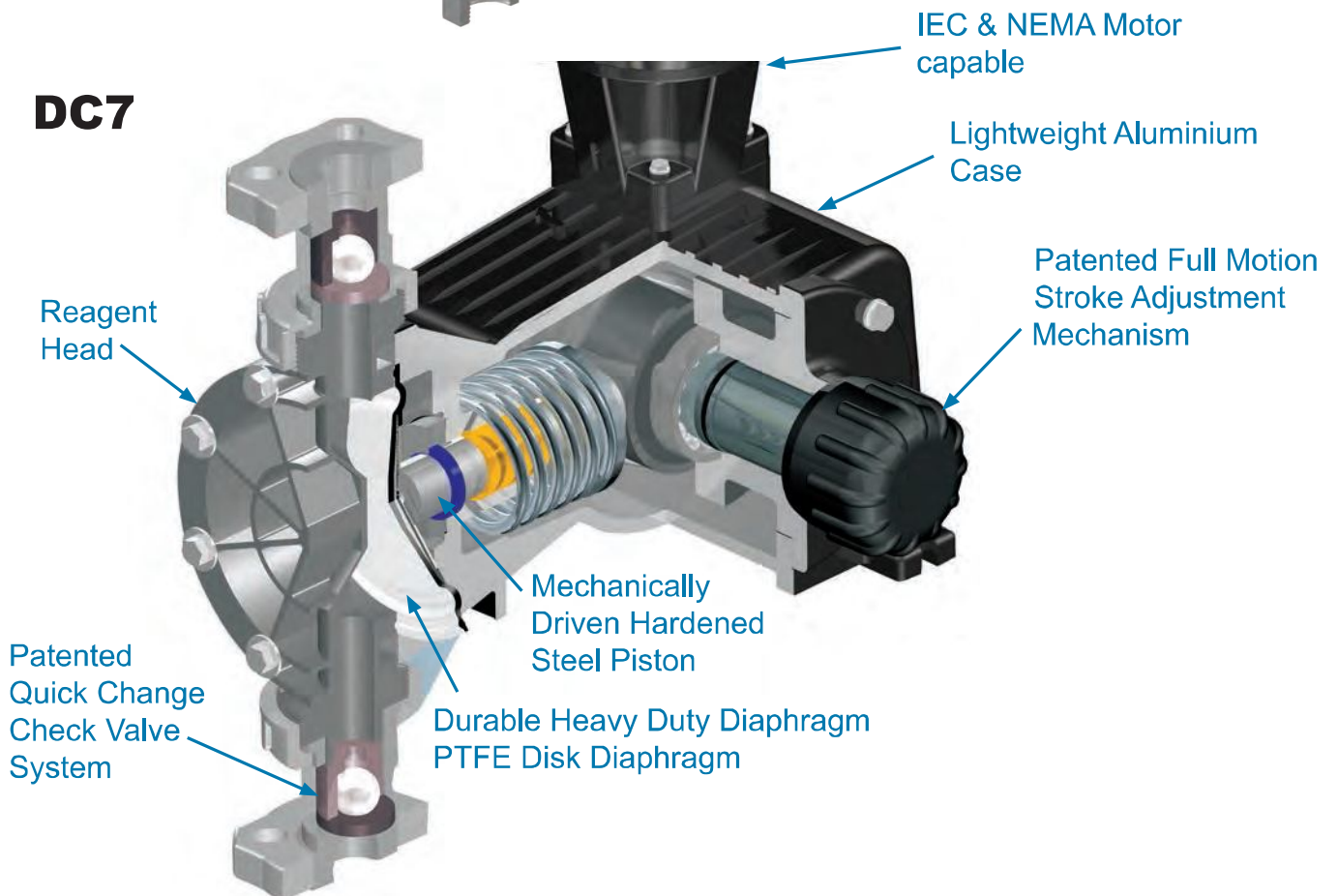

Control Options

For high technology in a simple to understand package at an economical price, add an MPC to the OMNI pump to take advantage of a complete system integration between metering pump and process.



Metering Pump Controller

(Models DC 2-6 only)

- Automatically controls and displays flow with a 4-20 mA input, handheld keypad, and manual stroke control
- Controls Pulsafeeder metering pumps up to 1000:1 turn down ratio
- The IP56 (NEMA 4X) Handheld user interface is attached to the pump with 4.5 feet (1.5 meters) of cable
- Optionally, the Handheld can be mounted up to 1000 feet (304 meters) away from the pump
- Handheld displays flow rate of the pump in LPH or GPH



- Use digital inputs and outputs to monitor and control :
 - Supply tank level
 - Pump flow verification
 - Remote status indication of pump (on/off)
 - Pump alarm status
 - Pump auto/manual status



Systems

When used in a system, the OMNI Pump can be used in applications such as:

- Water Conditioning Service-Chlorination
- Water Treatment Service-Odor Control
- Wastewater Service-Polymer Injection
- Process pH Treatment-Acids & Caustics
- Process Water-Corrosion Inhibitor

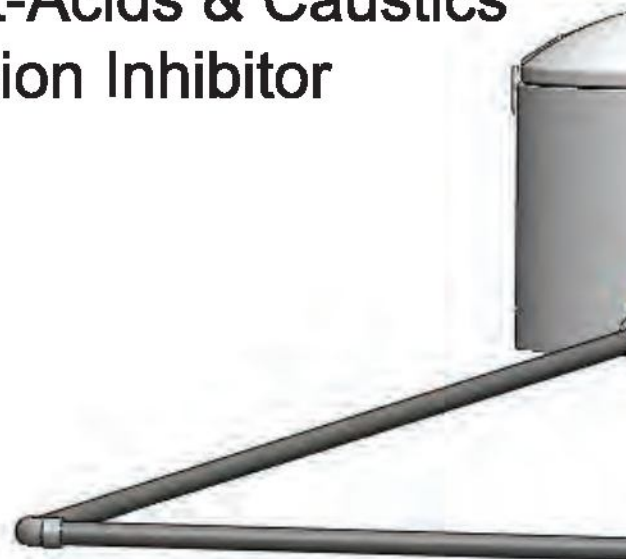

Parts & Accessories



A **KOPkit (Keep On Pumping)** can help you cut downtime and put you back in business fast. Use KOPkits for preventive maintenance and to ensure continuous high performance from your Pulsafeeder metering pump.

Pressure Relief Valves

prevent an overpressurization situation from ever damaging your pumps or pipes. Overpressurization can occur when a valve is closed or a blockage occurs. They are always recommended equipment for any pump or skid system.



Pulsafeeder's **Pulsation Dampeners** improve pump system efficiency by removing pulsating flows from positive displacement pumps.



PulsaLube is the only oil Pulsafeeder recommends for use in metering and transfer pumps. PulsaLube is a superior blend of oils designed to provide optimal lubrication and extend equipment life.



Calibration Columns

These columns are constructed of clear PVC tubes with PVC end caps or an option for Borosilicate glass with Teflon end caps and should be sized for a 30-second draw down.



Pressure Gauges are relied on to measure pressure in the system. Proper pressure is necessary to insure flow. Pulsafeeder Pressure Gauges are accurate and reliable.



Back Pressure Valves provide positive back pressure for systems with less than the minimum required pressure difference between the discharge and suction side of the metering pump to assure best metering performance.



2883 Brighton-Henrietta Townline Road
Rochester, NY 14623
Phone: +1 585-292-8000
Fax: +1 585-424-5619

An ISO 9001 and ISO 14001 Certified Company

pulsafeeder.com



OMS08 G10