



TECHNICAL CHARACTERISTICS

- Aluminium alloy construction
- Smooth operation
- High efficiency impeller
- Maintenance free
- Mountable in any position

OPTIONS

- Special voltages (IEC 38)
- Surface treatments

Possible alternative positions, please refer to drw SI 1818

Dimensions in mm.
Dimensions for reference only.

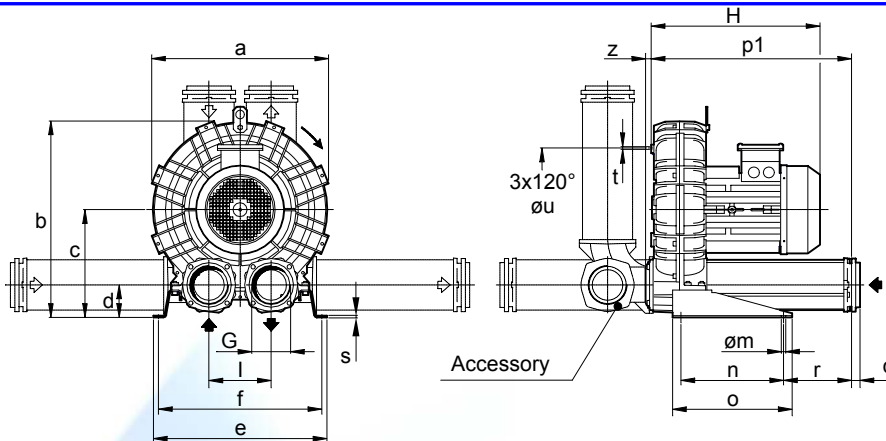

Model	a	b	c	d	e	f	G	l	m	n	o	p1	q	r	s	t	u	z
K07-MS	424	481	269	82	468	438	G 3"	155	13	300	350	512	25	137	5	M8	295	16
K75-MS	424	481	269	82	468	438	G 3"	155	13	300	350	512	25	137	5	M8	295	16
K08-MS	457	498	269	82	478	448	G 3"	155	13	300	350	512	25	137	5	M8	310	16
K09-MS	492	561	315	96	508	478	G 4"	182	13	300	350	586	25	199	5	M8	360	16
K10-MS	516	573	315	96	508	478	G 4"	182	13	300	350	586	25	199	5	M8	360	16
K11-MS	542	603	332	91	538	508	G 4"	200	13	300	350	596	25	204	5	M8	390	16

Model	Maximum flow m³/h		Installed power kW		Maximum differential pressure Δp hPa (mbar)		Noise level Lp dB (A) (1)		Overall dimensions H mm	Weight Kg
	50 Hz 2900 rpm	60 Hz 3500 rpm	50 Hz 2900 rpm	60 Hz 3500 rpm	50 Hz 2900 rpm	60 Hz 3500 rpm	50 Hz 2900 rpm	60 Hz 3500 rpm		
K07-MS	414	500	2.2	2.55	130	100	76.4	78.4	410	46.5
			3.0	3.45	200	175	76.7	78.7	410	47.5
			4.0	4.6	280	250	77.0	79.0	410	51.0
			5.5	6.3	400	375	77.3	79.3	445	61.5
			-	8.7	-	450	-	79.6	445	66.5
K75-MS	477	576	4.0	4.6	150	100	77.4	79.4	410	51.5
			5.5	6.3	250	200	77.7	79.7	445	62.0
			7.5	8.7	325	300	78.0	80.0	445	67.0
			-	10.6	-	400	-	80.3	480	76.5
K08-MS	536	647	3.0	3.45	125	100	77.4	79.4	410	49.0
			4.0	4.6	180	150	77.7	79.7	410	52.5
			5.5	6.3	275	250	78.0	80.0	445	63.0
			7.5	8.7	400	375	78.3	80.3	445	68.0
			9.2	10.6	450	450	78.6	80.6	480	77.5
K09-MS	663	800	4.0	4.6	130	85	78.0	80.0	420	62.0
			5.5	6.3	210	150	78.2	80.2	455	72.5
			7.5	8.7	290	250	78.5	80.5	455	77.5
			9.2	10.6	350	325	78.7	80.7	490	87.0
			11	12.7	450	400	79.0	81.0	490	87.5
			-	17.4	-	500	-	81.3	490	92.5
K10-MS	782	944	5.5	6.3	160	115	78.1	80.1	455	75.0
			7.5	8.7	250	200	78.5	80.5	455	80.0
			9.2	10.6	300	270	79.0	81.0	490	89.5
			11	12.7	400	375	79.4	81.4	490	90.0
			15	17.4	500	500	79.6	81.6	490	95.0
K11-MS	915	1105	5.5	-	100	-	78.5	-	460	78.5
			7.5	8.7	175	130	80.0	82.0	460	83.5
			9.2	10.6	230	175	80.1	82.1	495	93.0
			11	12.7	300	250	80.4	82.4	495	93.5
			15	17.4	400	350	80.7	82.7	495	98.5
			18.5	21.5	500	500	83.6	85.6	590	128.5

(1) Noise measured at 1 m distance with inlet and outlet ports piped, in accordance to ISO 3744.

- For proper use, the blower should be equipped with inlet filter and safety valve; other accessories available on request.
- Ambient temperature from -15° to +40°C.
- Specifications subject to change without notice.



LATERAL CHANNEL BLOWERS - COMPRESSORS SCL K07 / K75 / K08 / K09 / K10 / K11

MS SERIES - MOR RANGE

SN 1801-7 2/2

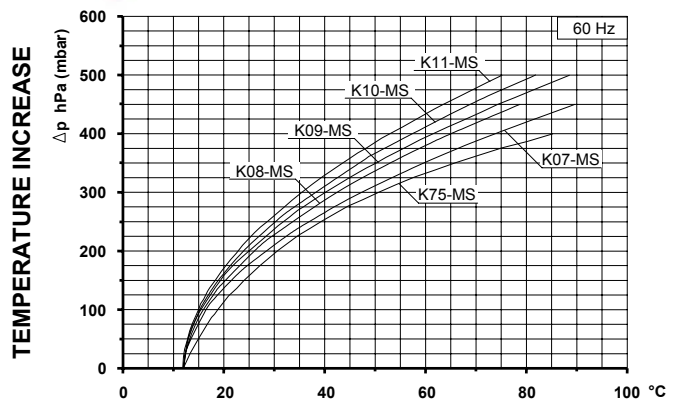
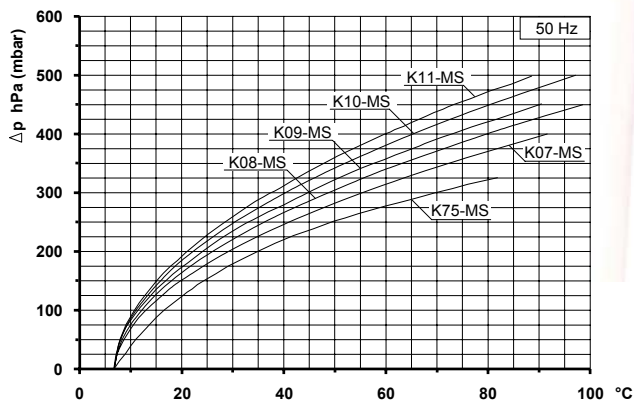
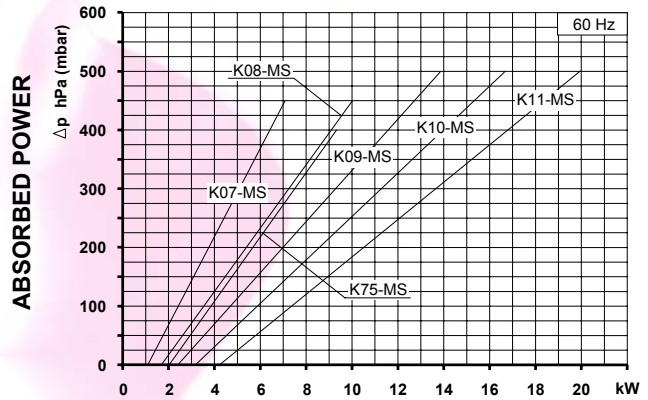
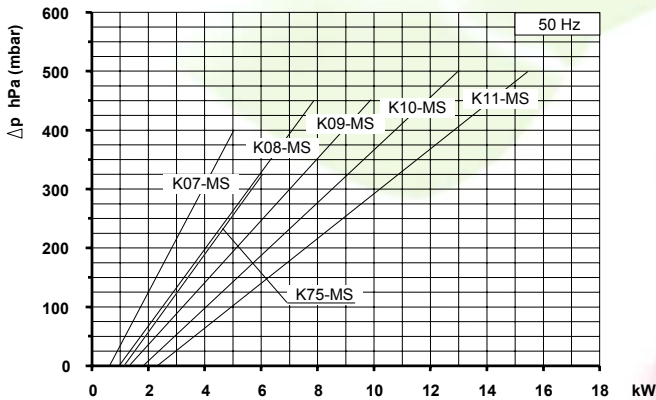
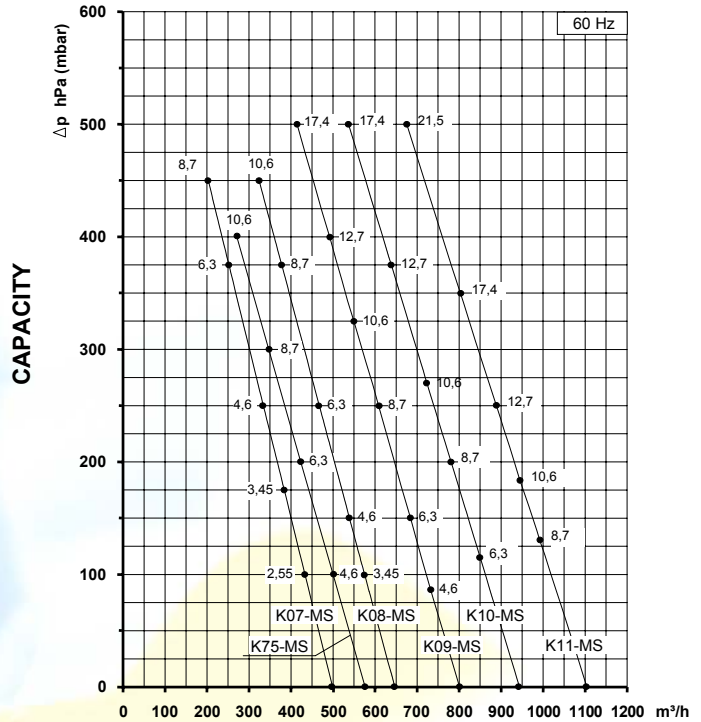
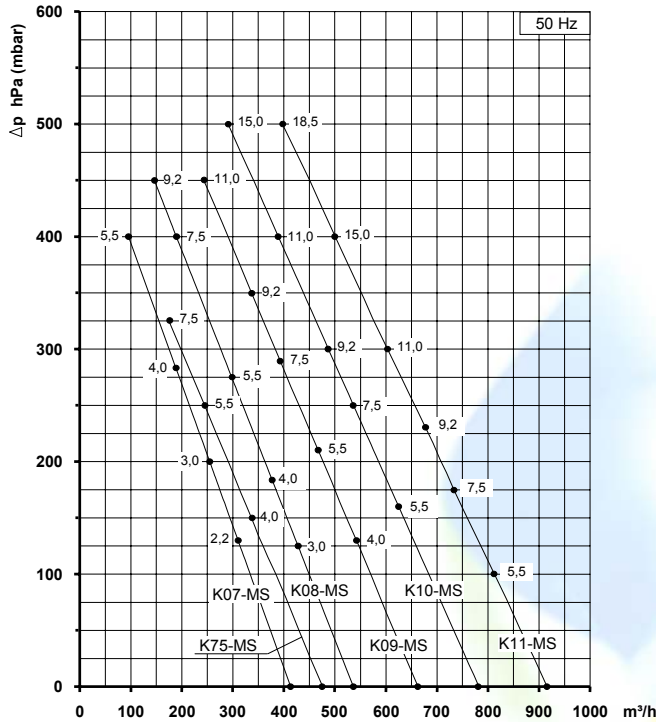

Curves refer to air at 20°C temperature and 1013 mbar (abs) atmospheric pressure measured at inlet port.
Tolerance on given values: ± 10%.
Data can change without prior notice.