

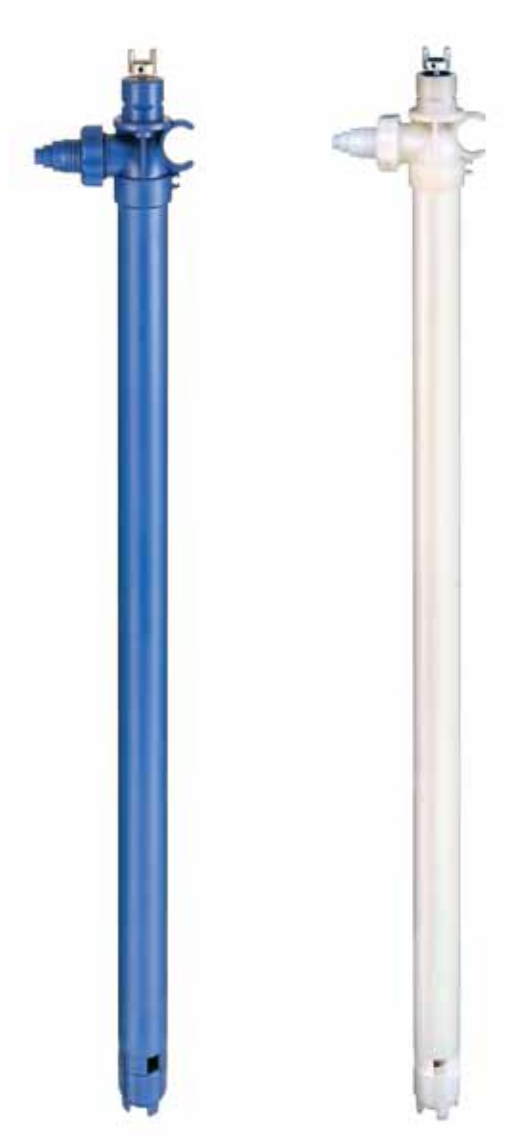

FINISH THOMPSON INC.

# **PF SERIES PUMPS**

## **PFM, PFP, PFV OPERATION, INSTALLATION & PARTS MANUAL**





**FINISH THOMPSON INC.**  
921 Greengarden Road • Erie, PA 16501-1591 U.S.A.  
Ph 814-455-4478 • Fax 814-455-8518  
Email [fti@finishthompson.com](mailto:fti@finishthompson.com) • [www.finishthompson.com](http://www.finishthompson.com)

## EU Declaration of Conformity



Finish Thompson Inc. hereby declares that the following machine(s) fully comply with the applicable health and safety requirements as specified by the EC Directives listed. The product may not be taken into service until it has been established that the drive motor for the Drum and Container Pump complies with the provisions of all relevant EC Directives. The complete product complies with the provisions of the EC Directive on machinery safety provided motors manufactured by Finish Thompson Inc. are used. This declaration is valid provided that the devices are fully assembled and no modifications are made to these devices.

### Type of Device:

Drum and Container Pump Tubes

### Models:

BTS - 40		EPPI/EPPS 15/27/40	EFP/EFV/EFS-16/27/40/48
HVDP LR-27/40/48	HVDP	HR-27/40/28	PFM-27/40/48/60
PFP-15/27/40/48/60/72		PFS-27/40/48/60/72	PFV-27/40/48/60/72
TBP-27/40/48	TBS-40		-27/40/48
STTS-40	TMS-40	TTC/TTS	

### EC Directives:

Machinery Safety (2006/42/EC)

### Applied Harmonized Standards:

EN ISO 12100 Part 1  
EN ISO 12100 Part 2  
EN 809

Manufacturer:

Finish Thompson Inc.  
921 Greengarden Road  
Erie, Pennsylvania 16501-1591 U.S.A

Signed,

\_\_\_\_\_  
President

January 7, 2013

Person(s) Authorized to Compile Technical File: Michael Smith Engineers Limited  
Oaks Road, Woking, Surrey  
GU21 6PH, UK  
Telephone: 01483 771871

# Introduction

This manual pertains to the PF Series, specifically the PFP, PFM, and PFV plastic drum pumps. Finish Thompson Inc. thanks you for choosing our products. We believe the use of our products will be fully satisfactory. When properly installed and operated, your Finish Thompson motor and pump will provide long, trouble-free service; therefore, please read this manual carefully before carrying out any operations on the pump/motor unit. Any use other than that described herein is considered incorrect; and, consequently, Finish Thompson Inc. shall not be held responsible for any damages to people or property. In case of doubt or enquiries, please reply to our Technical Service department directly at the following address:

Finish Thompson, Inc.  
921 Greengarden Rd.  
Erie, PA 16501 U.S.A.  
Tel. 1-814-455-4478; Fax 1-814-455-8518  
[www.finishthompson.com](http://www.finishthompson.com); [fti@finishthompson.com](mailto:fti@finishthompson.com)

## Index

Introduction .....	1
Warranty, General Terms & Conditions.....	2
Safety .....	3
Pump Specifications .....	4
Installation.....	5
Maintenance	
Disassembly .....	5
Inspection .....	6
Reassembly .....	6
Exploded View .....	7
Design Change .....	8
Pump Tube Spare Parts List .....	9-10

**Technical Service Hotline:** 1-800-888-3743 or email [techservice@finishthompson.com](mailto:techservice@finishthompson.com)

# Warranty, General Terms & Conditions

1. The following terms and conditions apply to the sale of machinery, components and related services and products, of Finish Thompson Inc. (hereinafter “the products”)
2. Finish Thompson Inc. (the manufacturer) warrants only that:
  - a) its products are free of defects in material, design and workmanship at the time of original purchase;
  - b) its products will function in accordance with Finish Thompson Inc. operation manuals; Finish Thompson Inc. does not guarantee that the product will meet the precise needs of the Customer, except for those purposes set out in any invitation to render documents or other documents specifically made available to Finish Thompson Inc. before entering into this agreement;
  - c) high quality materials are used in the construction of the pumps and that machining and assembly are carried out to the highest standards. Except as expressly stated above, Finish Thompson Inc. makes no warranties, express or implied, concerning the products, including all warranties of fitness for a particular purpose.

This warranty shall not be applicable in circumstances other than defects in material, design, and workmanship. In particular warranty shall not cover the following:

- d) Periodic checks, maintenance, repair and replacement of parts due to normal wear and tear;
- e) Damage to the product resulting from:
  - i. Tampering with, abuse or misuse, including but not limited to failure to use the product for its normal purposes as stated at the time of purchase or in accordance with Finish Thompson, Inc. instructions for use and maintenance of the product, or the installation or improper ventilation or use of the product in a manner inconsistent with the technical or safety standard in force;
  - ii. Repairs performed by non-authorized service workshop, or opening of the unit by non-authorized personnel, or use of non genuine Finish Thompson Inc. parts;
  - iii. Accidents, force majeure or any cause beyond the control of Finish Thompson Inc., including but not limited to lightning, water, fire, earthquake, and public disturbances, etc.
3. The warranty shall cover the replacement or repair of any part, which is documented to be faulty due to construction or assembling, with new or repaired parts free of charge delivered by Finish Thompson, Inc. Parts subjected to normal wear and tear shall not be covered by the warranty. Finish Thompson, Inc. shall decide as to whether the defective or faulty part shall be replaced or repaired. Transportation charges are prepaid to Finish Thompson.
4. The warranty of the products shall be valid for a period of **12 months** from the date of delivery, under the condition that notice of the alleged defect to the products or parts thereof be given to Finish Thompson, Inc. within the term of 8 days from the discovery.
5. Repair or replacement under the terms of this warranty shall not give a right to an extension to, or a new commencement of, the period of warranty. Repair or replacement under the terms of this warranty may be fulfilled with functionally equivalent re-conditioned units. Finish Thompson Inc. qualified personnel shall be solely entitled to carry out repair or replacement of faulty parts after careful examination of the motor. Faulty parts or components when replaced by Finish Thompson Inc. will become the property of Finish Thompson Inc. If this warranty does not apply, the purchaser shall bear all cost for labor, material and transportation.
6. Finish Thompson Inc. will not be liable on any claim, whether in contract, tort, or otherwise, for any indirect, special, incidental, or consequential damages, caused to the customer or to third parties, including loss of profits, process down time, transportation costs, costs associated with replacement or substitution products, labor costs, installation or removal costs. In any and all events, manufacturer’s liability shall not exceed the purchase price of the product and/or accessories.
7. **Return Policy.** Should you have any problems with this product, please contact the distributor in your area. The distributor will determine if a return to the factory is necessary and will contact the factory for a Return Authorization Number. Otherwise, contact our Technical Service Hotline (1-800-888-3743) or e-mail [techservice@finishthompson.com](mailto:techservice@finishthompson.com) if you have any questions regarding product operation or repair.

# Safety

## 1. Introduction

This manual contains all the information needed for the correct installation, use and maintenance of your new Finish Thompson pump. It should be read and understood by all the personnel involved in installation, operating and servicing of the pump before it is started.

## 2. Operator Qualification and Training

The personnel in charge of the installation, the operation, and the maintenance of the pump must be qualified and able to perform the operations described in this manual. Finish Thompson, Inc. shall not be held responsible for the training level of personnel and for the fact that they are not fully aware of the contents of this manual.

## 3. Safety Instructions

### FOR YOUR OWN SAFETY

BEFORE using or servicing your pump, please make sure to wear the proper clothing, eye protection and follow standard safety procedures when handling corrosive or personally harmful materials.

### GENERAL DANGER

**NEVER** use a plastic pump or an open, splash-proof, TEFC or non-ATEX motor when pumping or mixing flammable or combustible material.

**ALWAYS** use and store the pump and motor in an upright position.

### DANGER: POWER SUPPLY

Refer to instructions in the appropriate motor Operation & Installation Manual.

## 4. Noise Level

Refer to specifications in the appropriate motor Operation & Installation Manual.

## 5. Modifications and Spare Parts

Any changes concerning the service of the pump as originally purchased can be executed only after written approval from Finish Thompson Inc. It is recommended to use only genuine Finish Thompson Inc. spare parts and approved accessories. The use of non-original spare parts or non-approved accessories will void warranty and removes any responsibility on the manufacturer's behalf for any damage caused to people or things.

### PUMP SPECIFICATIONS

	MODEL PFM	MODEL PFP	MODEL PFV
Outer Tube Diameter	2" (51 mm)	2" (51 mm)	2" (51 mm)
Discharge Spout	Variable orifice barb fitting	Variable orifice barb fitting	Variable orifice barb fitting
Discharge Thread	1-1/4" NPSM	1-1/4" NPSM	1-1/4" NPSM
Max. Specific Gravity	1.83	1.83	1.83
Max. Viscosity	2000 cP	2000 cP	2000 cP
Min./ Max. Fluid Temperature	35°F Minimum to 160°F Maximum	35°F Minimum to 160°F Maximum	35°F Minimum to 120°F Maximum*
	(1.6°C Minimum to 71°C Maximum)	(1.6°C Minimum to 71°C Maximum)	(1.6°C Minimum to 49°C Maximum)
Wetted Materials	Polypro, FKM, PTFE, ETFE, 316 SS	Polypro, FKM, PTFE, ETFE, Alloy 625 (PFP)	Unfilled Polypro, PVDF, FKM, PTFE, ETFE, Alloy 625

\*PFV-72: 35°F Min. to 115°F Max. (2°C Min. to 49°C Max.)

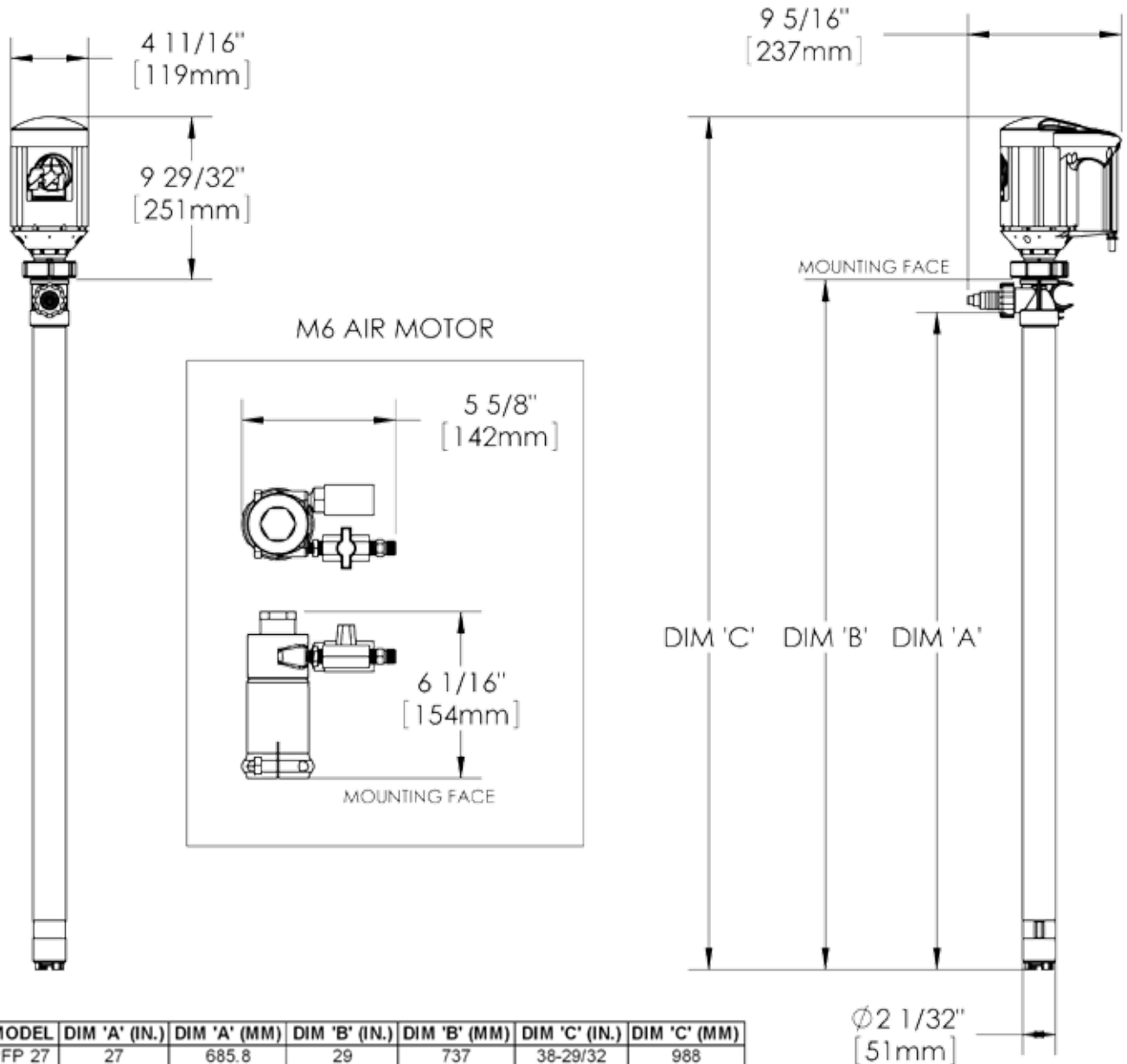

MODEL	DIM 'A' (IN.)	DIM 'A' (MM)	DIM 'B' (IN.)	DIM 'B' (MM)	DIM 'C' (IN.)	DIM 'C' (MM)
PFP 27	27	685.8	29	737	38-29/32	988
PFP 40	40	1016	42	1067	51-29/32	1318
PFP 48	48	1219.2	50	1270	59-29/32	1522
PFP 60	60	1524	62	1575	71-29/32	1826
PFP 72	72	1828.8	74	1880	83-29/32	2131

# INSTALLATION & MAINTENANCE INSTRUCTIONS

## Installation

1. Remove the drum pump from its packaging and inspect for shipping damage.
2. Turn the pump coupling to verify there is no binding.
3. Verify the housing cover (item 21) is on tight (it has a left hand thread).
4. Adjust the coupling so that the empty slots in the insert are at 3 and 9 o'clock with the pump discharge at 12 o'clock.
5. Install the motor onto the drum pump per the installation instructions from the Operation & Installation Manual of the specific motor model.

**Note:** Pumps with the standard 1" barb spout include a variable orifice fitting, which initially limits the flow of the pump to 10 gpm. As it is cut away, flow will increase from 10 gpm up to maximum flow (to increase flow, simply trim back orifice). Orifice steps control flow as follows: Step 1 = 10 gpm, Step 2 = 20 gpm, Step 3 = 30 gpm, Step 4 (maximum opening) = maximum flow (see Fig. 1).

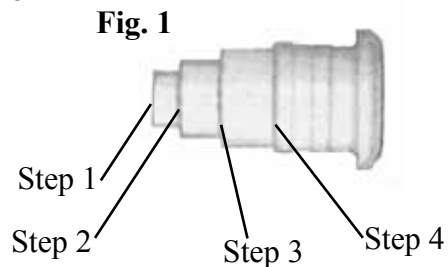

**Note:** ALWAYS use a 1" I.D. hose properly secured to the barb spout using a hose clamp.

## Maintenance

### Disassembly

1. Remove the housing cover (item 21) by turning it clockwise (left hand thread) while gripping the impeller housing (item 18).
2. Turn the impeller until a hole in the shaft can be seen through the square slot in the impeller housing (item 18), and insert 3/32 pin into the hole. Holding the pin, turn the impeller (item 20) counterclockwise (right-hand thread) and remove it.
3. Remove the impeller housing (item 18) by gripping the intake tube and spinning the housing clockwise (left hand thread). Re-insert the 3/32 pin and while gripping the pump coupling unthread (counterclockwise) and remove the shaft (item 19) from the bearing assembly (item 3).
4. Place the pump head (item 5) in a vise (do not crush) and remove the intake tube (item 9) by unthreading clockwise (left hand thread). Remove the inner upper (item 11) and lower (item 15) tubes from the head. Remove the bearing assembly (item 3) and the FKM lip seal (item 4) from the head.
5. Remove the center bearing (item 13) from the upper (item 11) and lower (item 15) tubes.

## Inspection

1. Check the housing cover (item 21), the impeller (item 20), and the impeller housing (item 18) for wear, rubbing, or damage from foreign objects. Replace if damaged.  
**Note:** The double impeller design of this pump is dependant on the impeller working correctly. Any damage to the impeller can cause pump failure.
2. Inspect the pump shaft (item 19) for wear in the bottom (item 16), center bearing (item 13) and the FKM lip seal (item 4) areas. Replace the shaft if needed.
3. Inspect the bottom bearing (item 16), center bearing (item 13), and the bearing guide (item 14) for internal wear. Inspect all o-rings (items 17,12, & 10) for nicks or chemical attack. Replace as needed.
4. Inspect the bearing assembly (item 3) for rust or corrosion. Never reuse the lip seal.

## Reassembly

1. Install new lip seal (item 4) into the pump head with the grooved side facing the bottom of the pump.
2. Thread the shaft (item 19) into the bearing assembly (item 3) with the 3/32 hole in the shaft on the other end. Carefully insert the shaft straight through the vapor seal (to avoid seal damage) from the top and seat the bearing assembly (item 3) into the pump head.
3. If o-rings are replaced -- install 2 center bearing o-rings (items 12) in the grooves, then slide the bearing guide on and then the remaining 2 o-rings. Install 2 upper inner tube o-rings (items 10), and install the impeller housing o-ring (item 17) inside the top of the housing. Apply a small amount of Vaseline to the o-rings to aid in assembly. Assemble the center bearing (item 13) into the upper (item 11) and lower (item 15) inner tubes.
4. Slide the inner tube assembly up the shaft and into the counter bore in the bottom of the head. Slide the intake tube up from the bottom, centering the bearing guide, and thread it into the head (left hand thread).
5. Gripping the coupling at the top of the pump, thread the impeller on (right hand thread). Install the housing cover (left hand thread). Turn the coupling to verify there is no binding inside the pump.



# PFM/PFP/PFV SPARE PARTS EXPLODED VIEW

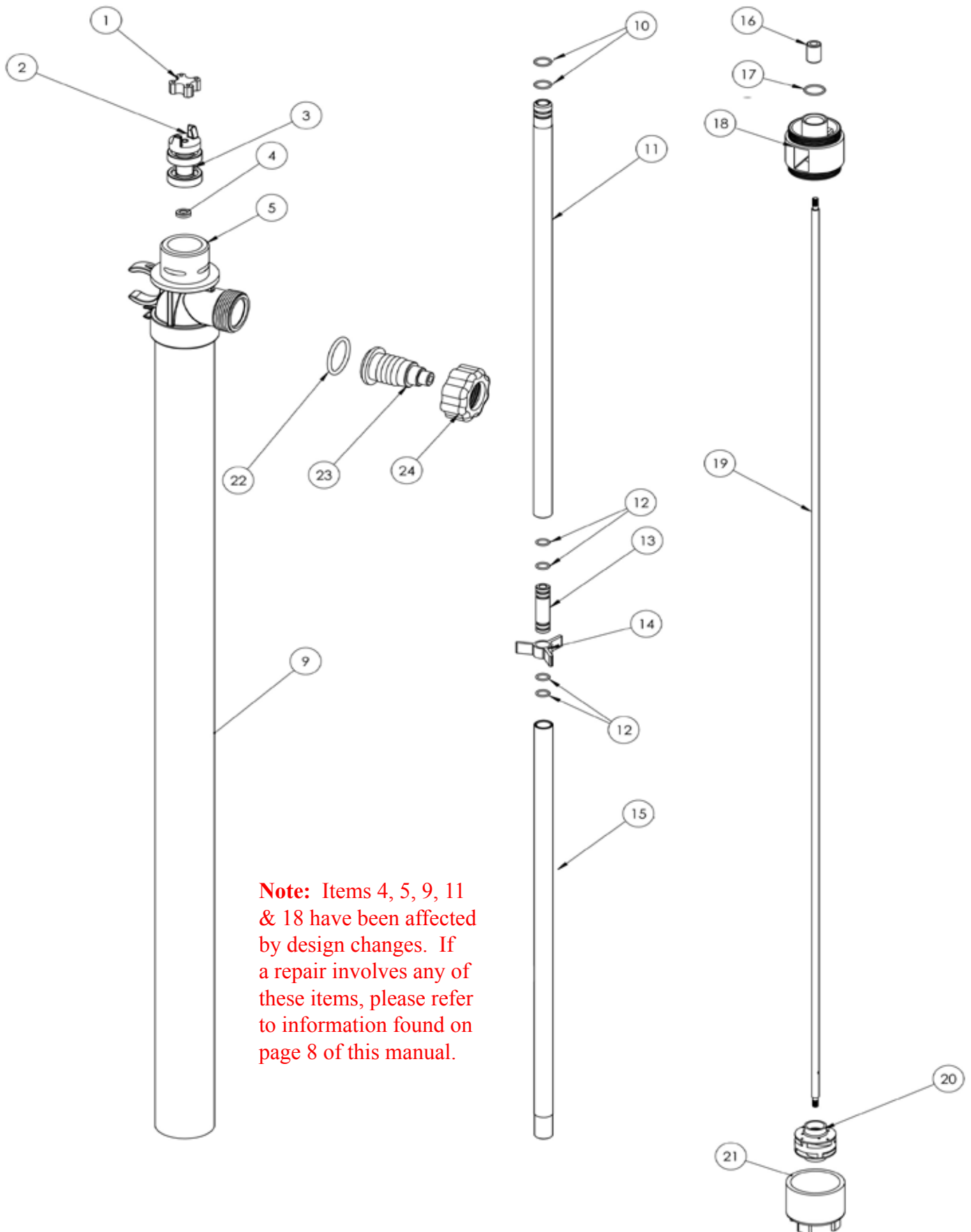

**Note:** Items 4, 5, 9, 11 & 18 have been affected by design changes. If a repair involves any of these items, please refer to information found on page 8 of this manual.

Not Pictured: Item 25 (Middle Inner Tube - 60" & 72" pump lengths only) & Item 26 (Lower Middle Inner Tube - 72" pump length only)

## Impeller Housing change - PFM, PFP, PFV Series

Beginning August 2010, Finish Thompson made a change to the impeller housing (item 18) on the plastic PF Series models (PFM, PFP, PFV). The change was phased in over several months and covers all the various tube lengths within these models.

The change affects these parts:

- Intake tube assembly (item 9)
- Upper inner tube (item 11)
- Impeller housing (item 18)

When repairing a pump involving the parts listed above, you must **assure that the correct parts are ordered.**

**First - check the serial number.** If the pump serial number ends in L10 or older (pumps manufactured before January 2011), it is necessary to determine which impeller housing is installed in the pump. If the serial number is not legible, the information below can be used to determine which impeller housing your pump contains.

NOTE: All pump serial numbers end with a letter and two digit number. The letters, A through L, refer to the month, e.g. A = January. The two numerical digits refer to year. So, a pump serial number ending in C08 was manufactured in March 2008.

**Second - determine impeller housing required.** The easiest way to determine new versus old is to measure one of the two "windows" in the side of the impeller housing. Measure from the top to the bottom. Old style impeller housings have a window height of approximately .7" (18 mm). New style impeller housings have a window height of approximately 1" (25 mm).

Impeller Housings

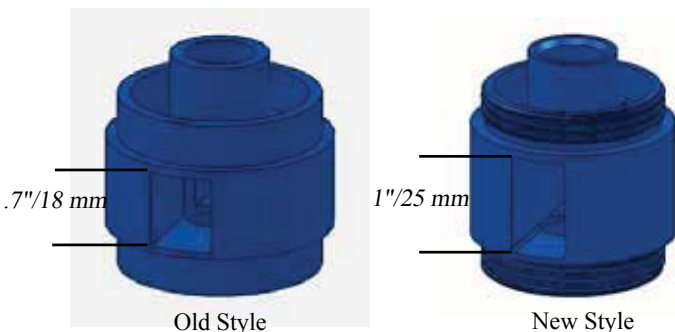

- If the pump has an old style impeller housing and one or all of the three affected parts are required for repair, find the correct part number in the parts list on this page.
- When ordering all other parts, reference the parts list on page 9 of this manual

Old Style Impeller Housing Parts List			
Item	Description	PFM/PFP	PFV
4	Vapor Seal*	M100008	M100008
9	27" Intake Tube	M100005-1	M100005-5
9	40" Intake Tube	M100005-3	M100005-6
9	48" Intake Tube	M100005-4	M100005-7
9	60" Intake Tube	M100005--8	M100005-12
9	72" Intake Tube	M100005-11	M100005-10
11	27" Upper Inner Tube	M100050-1	M100050-5
11	40" Upper Inner Tube	M100050-3	M100050-6
11	48" Upper Inner Tube	M100050-4	M100050-7
11	60" & 72" Upper Inner Tube	M100050-3	M100050-6
18	Impeller Housing	M100018-1	M100018-2

\*Vapor seal can also be purchased as a kit with the bearing assembly using part number 106567.

## Head and Vapor Seal Change - PFM, PFP, PFV Series

In October 2010, Finish Thompson made a change to the head (item 5) and the seal (item 4) on the plastic PF Series pumps. Make sure the correct parts are ordered when repairing a pump **Should you have a question about this change, please contact our Technical Service Department at 800-888-3743.**

### Vapor Seal

The primary part affected by the change to the head is the seal (item 4). Old style vapor seals will continue to be available to fit old style heads.

Determination of new versus old style vapor seal is easy. Simply look at the head design.

#### Heads



To replace an old style head vapor seal, order P/N M100008. Order P/N 107592 to replace a new style head lip seal. The **two seals are not interchangeable**, so it is important to order the correct part number.

### Head

New style heads (item 5) are backwards compatible. Because the seals are different between the two heads, the head is sold as a kit that includes both the head and the seal. Use head part numbers shown in the parts list on page 9 of this manual.

## PUMP SPARE PARTS LIST

ITEM	QTY	DESCRIPTION	PART NUMBER		
			MODEL PFM	MODEL PFP	MODEL PVF
1	1	<b>COUPLING INSERT</b>			
			J100014	J100014	J100014
2	1	<b>COUPLING HALF</b>			
			J100012	J100012	J100012
3*	1	<b>BEARING ASSEMBLY</b>			
			A101110	A101110	A101110
4*	1	<b>LIP SEAL</b>			
		1/4" FKM	107592	107592	107592
5	1	<b>NEW STYLE PUMP HEAD</b>			
		POLYPROPYLENE	107755-1	107755-1	N/A
		PVDF	N/A	N/A	107755-2
9	1	<b>INTAKE TUBE (PFM/PFP = POLYPROPYLENE, PVF = PVDF)</b>			
		27" MODELS	107475-2	107475-2	107475-7
		40" MODELS	107475-3	107475-3	107475-8
		48" MODELS	107475-4	107475-4	107475-9
		60" MODELS	107475-5	107475-5	107475-10
		72" MODELS	107475-6	107475-6	107475-11
10*	2	<b>UPPER INNER TUBE O-RING</b>			
		FKM	J100249	J100249	J100249
		EPDM	106519	106519	106519
		PERLAST	105621	105621	105621
11	1	<b>UPPER INNER TUBE (PFM/PFP = POLYPROPYLENE, PVF = PVDF)</b>			
		27" MODELS	107660-2	107660-2	107660-5
		40" MODELS	107660-3	107660-3	107660-6
		48" MODELS	107660-4	107660-4	107660-7
		60" MODELS	107660-3	107660-3	107660-6
		72" MODELS	107660-3	107660-3	107660-6
12*	4 (27"-48") 8 (60") 12 (72")	<b>CENTER BEARING O-RING</b>			
		FKM	J100018	J100018	J100018
		EPDM	106798	106798	106798
		PERLAST	105620	105620	105620
13	1 (27"-48") 2 (60"), 3 (72")	<b>CENTER BEARING</b>			
		PTFE	M100010	M100010	M100010
14	1 (27"-48") 2 (60") 3 (72")	<b>BEARING GUIDE</b>			
		POLYPROPYLENE	M101603-2	M101603-2	N/A
		PVDF	N/A	N/A	M101603-1
15	1	<b>LOWER INNER TUBE</b>			
		27" MODELS	M100003-1	M100003-1	M100003-5
		40" MODELS	M100003-3	M100003-3	M100003-6
		48" MODELS	M100003-4	M100003-4	M100003-7
		60" MODELS	M100003-3	M100003-3	M100003-6
		72" MODELS	M100003-3	M100003-3	M100003-3
16	1	<b>BOTTOM BEARING</b>			
		PTFE	M100007	M100007	M100007
17*	1	<b>IMPELLER HOUSING O-RING</b>			
		FKM	J100019	J100019	J100019
		EPDM	106799	106799	106799
		PERLAST	105622	105622	105622
18*	1	<b>IMPELLER HOUSING</b>			
		POLYPROPYLENE	107316-1	107316-1	N/A
		PVDF	N/A	N/A	107316-2
19	1	<b>MAIN SHAFT</b>			
		27" MODELS	M100004-5	M100004-1	M100004-1
		40" MODELS	M100004-7	M100004-3	M100004-3
		48" MODELS	M100004-8	M100004-4	M100004-4
		60" MODELS	M100004-12	M100004-9	M100004-9
		72" MODELS	M100004-13	M100004-11	M100004-11
20*	1	<b>IMPELLER ASSEMBLY</b>			
		PVDF	A100002-2	A100002-2	A100002-2
21*	1	<b>HOUSING COVER</b>			
			M101612-1	M101612-1	M101612-2

N/A = Not Applicable

ITEM	QTY	DESCRIPTION	PART NUMBER		
			MODEL PFM	MODEL PFP	MODEL PFV
22	1	<b>DISCHARGE O-RING</b>			
		FKM	J100991	J100991	J100991
		EPDM	J102378	J102378	J102378
		PERLAST	107017	107017	107017
23	1	<b>SPOUT</b>			
		1" BARB (STANDARD)	M100028-1	M100028-1	M100028-2
		3/4" BARB (OPTIONAL)	105439-1	105439-1	105439
		1" MNPT (OPTIONAL)	106599	106599	106599-1
24	1	<b>DISCHARGE NUT</b>			
		FOR USE WITH 1" OR 3/4" BARB SPOUT	M101610-1	M101610-1	M101610-2
		FOR USE WITH 1" MNPT SPOUT ONLY	106622	106622	106622-1
25 (not pictured)	1	<b>MIDDLE INNER TUBE (PFM/PFP = POLYPROPYLENE, PFV = PVDF)</b>			
		27" MODELS	N/A	N/A	N/A
		40" MODELS	N/A	N/A	N/A
		48" MODELS	N/A	N/A	N/A
		60" MODELS	M100003-3	M100003-3	M100003-6
		72" MODELS	M100003-3	M100003-3	M100003-6
26 (not pictured)	1	<b>LOWER MIDDLE INNER TUBE (PFM/PFP = POLYPROPYLENE, PFV = PVDF)</b>			
		27" MODELS	N/A	N/A	N/A
		40" MODELS	N/A	N/A	N/A
		48" MODELS	N/A	N/A	N/A
		60" MODELS	N/A	N/A	N/A
		72" MODELS	M100003-1	M100003-1	M100003-5

\*Recommended Spare Parts

**Note:** Bearing assembly and lip seal can be purchased as a kit using part number 108110.



**FINISH THOMPSON INC.**

Service 1-800-888-3743  
P/N 108097-WEB, Rev 1, 3-5-13