

NITRO

THE COMPACT MULTI-FEATURE WAREWASH DISPENSER

The NITRO Warewash Dispenser bridges the gap between compact basic dispensers and feature packed units too large for small kitchens. NITRO has the versatility to be used with or without a probe from the same unit and the flexibility to be used on a single tank, door or conveyor machine. NITRO delivers premium features in a compact size with reduced installation and maintenance requirements that significantly lower the total cost of ownership.



- PROBE OR PROBLESS OPERATION FROM THE SAME UNIT
- COMPACT SPLASH RESISTANT ABS ENCLOSURE
- PRE-WIRED POWER SUPPLY TO REDUCE INSTALLATION TIME
- WALL MOUNTING BRACKET FOR EASY INSTALLATION AND REMOVAL
- PASSWORD PROTECTED DIGITAL PROGRAMMING CAN BE PRE-PROGRAMMED FOR FASTER INSTALLATION
- BUILT-IN RACK COUNTER
- MULTILINGUAL DISPLAY – ENGLISH, SPANISH, FRENCH AND PORTUGUESE
- FEED RATE ADJUSTMENT ADAPTS TO SIZE OF MACHINE
- QUICK CHANGE PUMP COVER FOR TOOL-LESS TUBE CHANGING
- OPTIONAL MAGNETIC FIELD READER FOR EVEN FASTER AND SAFER INSTALLATION
- OPTIONAL INDUCTIVE PROBE FOR HARD WATER REQUIREMENTS



SANITIZER PUMP EASILY
INTEGRATES TO THE
NITRO OR NITRO EXPRESS

DEMA

NITRO

THE COMPACT MULTI-FEATURE WAREWASH DISPENSER



Quick change pump for faster service

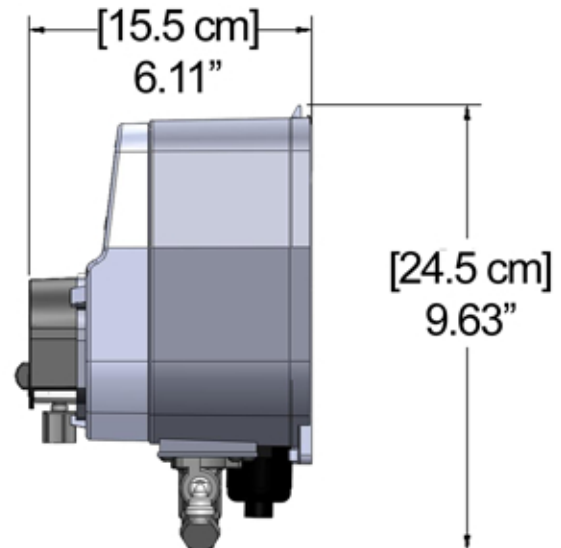
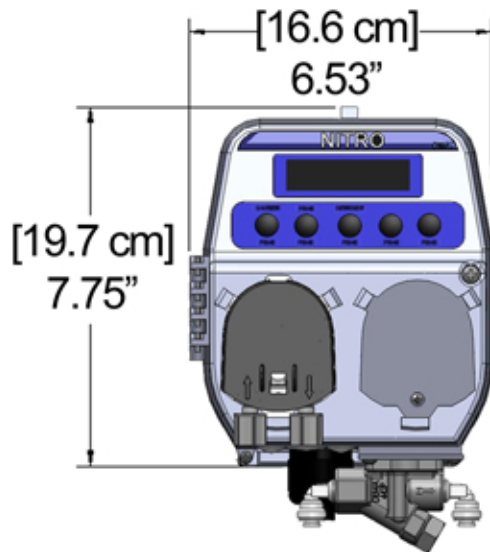

MODELS

Options	Liquid Detergent/Liquid Rinse Liquid Detergent/Rinse/Sanitizer	Dry Detergent/Liquid Rinse Dry Detergent/Liquid Rinse/Sanitizer
NITRO Part Numbers	N-LL-TA or N-LL-MA N-LLL-TA or N-LLL-MA	N-DL-TA or N-DL-MA N-DLL-TA or N-DLL-MA
Add-on Sanitizer Pump Part Numbers	O-ADC	(For N-LL-A and N-DL-A)

SPECIFICATIONS

Main Power	120-250V AC	50/60 Hz 1.5A
Motor/Solenoid Rating	24VDC	
Trigger Voltage	24-480V	
Case Material	ABS	
Environmental Temp	32-104°F	0-40°C
Detergent Pump Rate	6 oz/min	180 ml/min
Rinse Pump Rate	1.35 oz/min	40 ml/min
Sanitizer Pump Rate	1.35 oz/min	40 ml/min



NITRO

THE COMPACT MULTI-FEATURE WAREWASH DISPENSER



Pre-Installed Flux Sensors
Magnetic field reader
and pump activator
makes installation
safer and faster



Accessories included with the Nitro

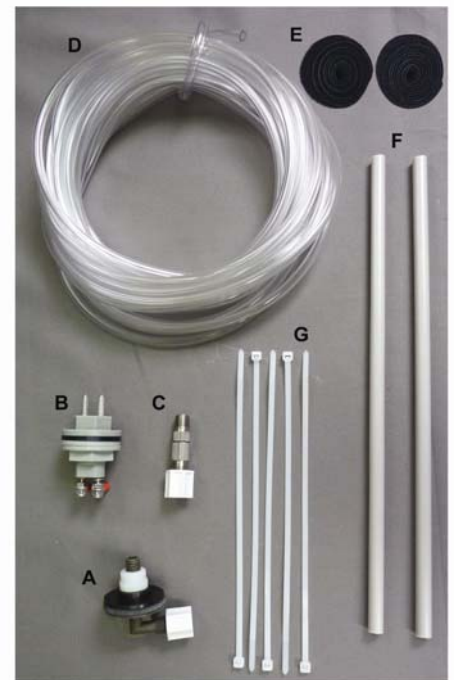

- A) Detergent injection fitting
- B) Detergent conductive probe
- C) Rinse injection fitting
- D) Chemical EVA tubing (10.6m)
- E) Velcro wrap for attaching flux sensors
- F) PVC tube stiffener for chemical tubing
- G) Wire ties

