

ANSI DIMENSIONAL MAGNETIC DRIVE PUMPS

ULTRACHEM[®]

Engineered for
EXTREME reliability
in chemical
processes.



FINISH THOMPSON INC.

Introduction

Ultra Reliable

Engineered for extreme reliability in the most extreme chemical processing applications, Finish Thompson's ULTRAChem® is a magnetically driven, ANSI dimensional pump constructed from tough ductile iron with DuPont Tefzel® (ETFE) lining for superior corrosion resistance.

Ultra Durable

Modified concentric volute, minimized hydraulic radial thrust loads, balanced hydraulic axial thrust loads, prevention of "pre-rotation" under low flows, reduced turbulence on the impeller, and optimum bushing alignment ... these are just some of the features designed into the ULTRAChem Series pumps to ensure optimum pump life.

Ultra Sealless

Powerful neodymium magnets drive the impeller through a carbon-filled ETFE lined barrier for dependable, leak-free operation with no environmental emissions, no double mechanical seal costs, and no seal support systems.

ULTRAChem® Circulation & Thrust Minimization

As the liquid flows through the suction and into the impeller (1), it accelerates to a high velocity and is pressurized, exiting the discharge (2). A small portion of the flow is re-directed to the rear of the impeller drive where it proceeds through the rear sealing ring (3), which minimizes axial impeller thrust. The flow then goes both around the bushings and through the spiral grooves in the bore of bushings (4) in order to enhance the flow, remove heat, and provide lubrication between the shaft and bushing bore, before emptying back into the impeller suction eye (5).

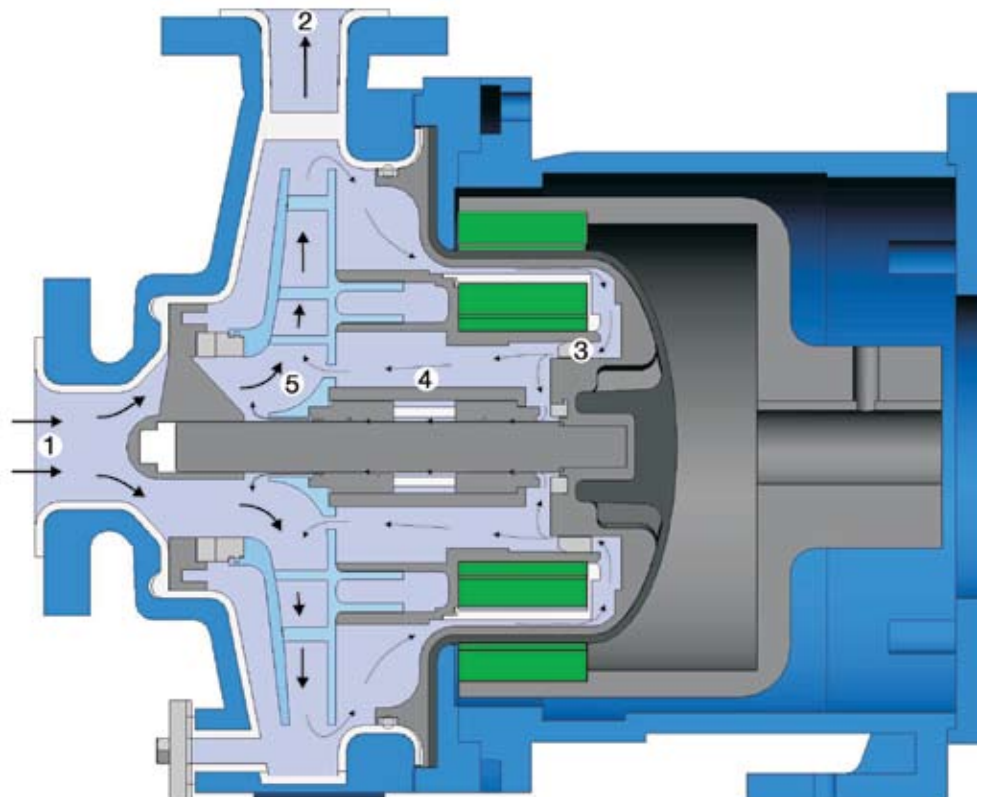

Tefzel® is a registered trademark of E. I. duPont de Nemours and Company.



	UC1516	UC1518	UC326
HP*	3-10	10-20	7 1/2 - 20
kW*	1.1 - 7.5	4.0 - 11.0	3.0 - 11.0
Imp. Dia (in.)**	4, 4 1/2, 5, 5 1/2, 6, 6 3/8	6, 6 1/2, 7, 7 1/2, 8 1/8	4 1/2, 5, 5 1/2, 6, 6 3/8
Imp. Dia. (cm) **	10.2, 11.4, 12.7, 14, 15.2, 16.2	15.2, 15.5, 17.8, 19, 20.6	11.4, 12.7, 14, 15.2, 16.2
Inlet x Outlet (in.)	1 1/2 x 1	1 1/2 x 1	3 x 2
Max. Flow	160 gpm (37 m ³ /hr)	160 gpm (37 m ³ /hr)	330 gpm (75 m ³ /hr)
Max. Head	180 ft (55 m)	325 ft (100 m)	165 ft (50 m)

* HP calculated at 3500 rpm. kW calculated at 2900 rpm.

** Impeller trims available every 1/8" (.32 cm) between the smallest and largest diameters.

NOTE: Max. flow and head calculated at 3500 rpm.

60 Hz, 3500 rpm

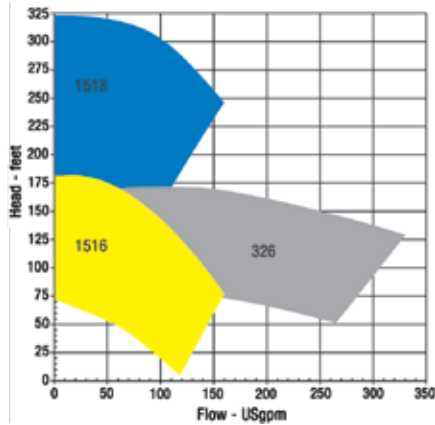

50 Hz, 2900 rpm

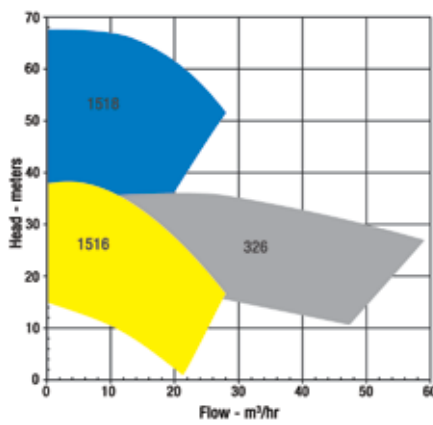

60 Hz, 1750 rpm

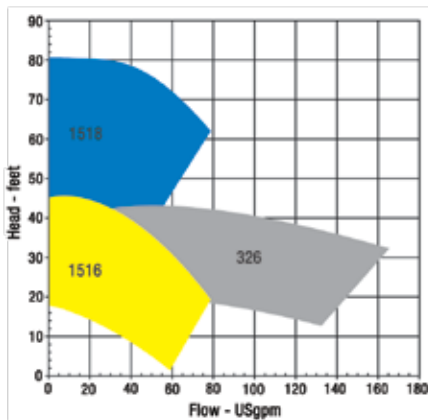

50 Hz, 1450 rpm

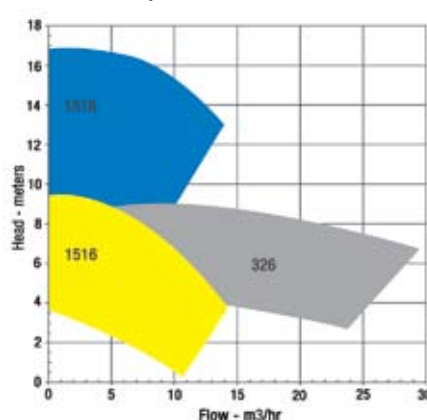

CAPABILITIES

Casing: ANSI/ASME B73.1m

Max. Working

Pressure: 175 psi (12 Bar)

Max. Temp.: 250°F (121°C)

Max. Viscosity: 200 cP

Flanges: ANSI or ISO

Casing: ANSI/ASME B73.1m

Motor Frames:

NEMA: 143, 184, 215, 256

IEC: 80, 90, 110/112, 132, 160

TYPICAL APPLICATIONS

- Chemical manu- facturing, blending, distribution
- Water treatment
- Plating and metal finishing
- Paper mills
- Fume scrubbers
- Metals manufacturing
- Electronics
- Pharmaceuticals
- Biodiesel

TYPICAL CHEMICALS

- Sodium hydroxide, sulfuric acid, hydrochloric acid, sodium hypochlorite, plating solutions, corrosive blends, wastewater, solvents

Modified Concentric Volute



The **modified concentric volute** minimizes radial loads and distributes pressure evenly across the entire flow range for less stress and wear on components.

Casing meets ANSI B73.1 dimensional requirements for foot and flange.



Item	Description	Construction Features
1	Casing	Cast ductile iron, lined with DuPont Tefzel®
2	Shaft Support	Carbon-filled ETFE
2A	Front thrust ring	Alpha sintered silicon carbide
3	Impeller Assembly	Enclosed impeller injection molded from carbon fiber reinforced ETFE.
3A	Impeller thrust ring	Fluorosint®. Alpha sintered silicon carbide optional.
4	Impeller Drive Hub	Carbon fiber-filled ETFE with neodymium iron boron magnets encapsulated in pure ETFE.
4A	Bushings	Alpha sintered silicon carbide bushings.
4B	& Spacer	Carbon bushing optional. PTFE spacer.

4C	Rear Sealing Ring	Molybdenum disulfide filled PTFE
5	Shaft	Replaceable alpha sintered silicon carbide
6	Barrier	Molded carbon fiber-filled ETFE liner with woven glass-reinforced vinyl ester external shell.
6A	Rear Thrust Ring	Alpha sintered silicon carbide
7	Clamp Ring	Steel
8	Drive Assembly	Nickel-plated neodymium iron boron magnets/ heavy duty ductile iron.
9	Motor Adapter	Heavy duty ductile iron.
10	Motor Adapter Flange	Steel
11	Drain Plug	304 stainless steel/Gylon® gasket
12	O-ring	Viton®, EPDM, Kalrez®, Simriz®

Viton® and Kalrez® are registered trademarks of DuPont Performance Elastomers. Simriz® Perfluoroelastomer is a registered trademark of the Simit® division of Freudenberg-NOK. Gylon® is a registered trademark of Garlock Sealing Technologies®.

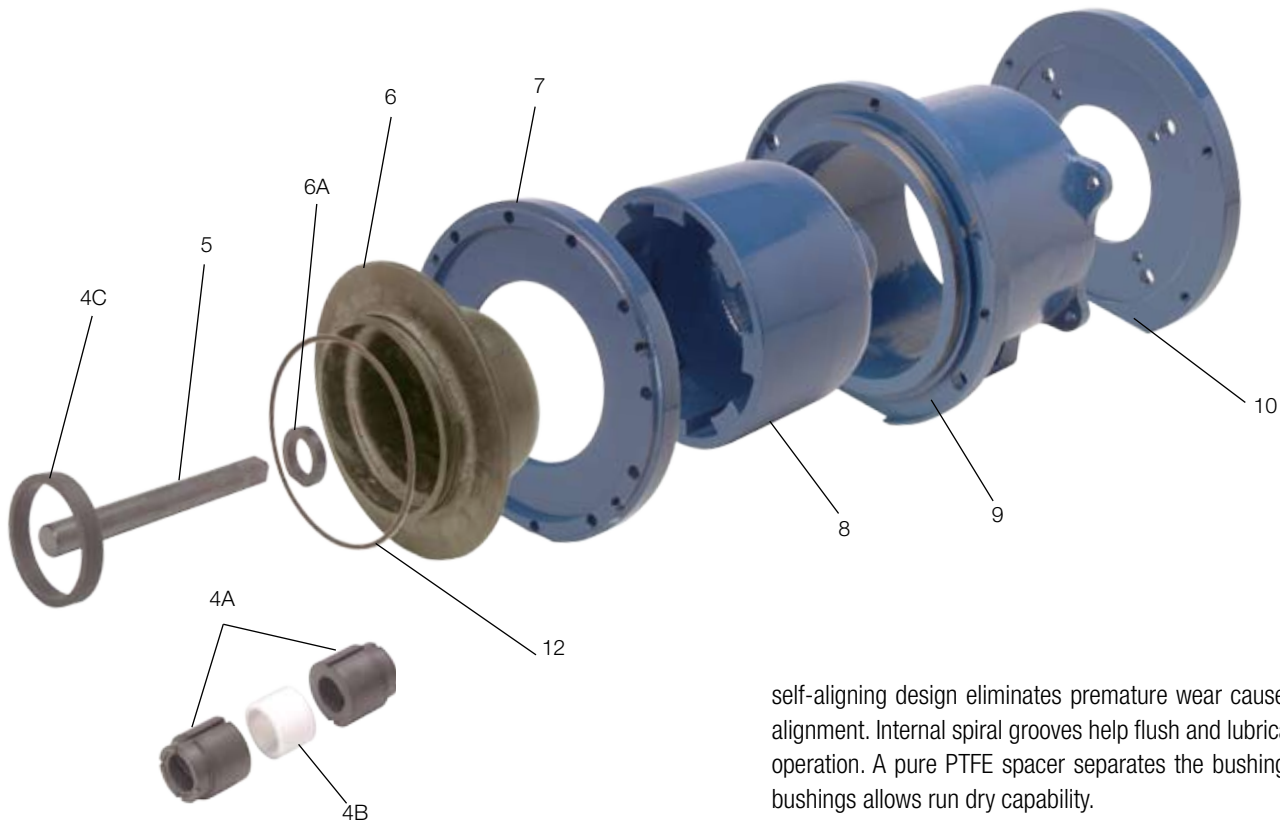

Casing (1, 2, 2A, 11)

High strength ductile iron bonded with pure Tefzel® for exceptional corrosion resistance. ANSI dimensional design with self-venting top center line discharge. Premium alpha sintered silicon carbide thrust washer and replaceable carbon-filled ETFE shaft support with integral straightening vanes help prevent pre-rotation in the suction and enhance low flow operation.

Impeller and Internal Drive (3, 3A, 4, 4C)

Enclosed impeller is injection molded from carbon fiber reinforced ETFE for superior chemical resistance and strength. Versatile lock-fit design allows removal of the impeller from the internal drive for lower maintenance costs. Rare earth magnets are encapsulated in pure ETFE for added protection against the most aggressive chemicals. The thrust balance system utilizes generous balance holes and a replaceable rear sealing ring with the same diameter as the impeller thrust ring to balance axial thrust. A replaceable Fluorosint® impeller thrust ring provides exceptional wear characteristics at all flows (also available in optional alpha sintered silicon carbide).

Magnets (4, 8)

High strength, rare earth neodymium iron boron magnets transmit maximum power up to 250°F (121°C). FTI's unique technology ensures an extraordinarily strong, secure coupling between the motor and pump. Sealless design virtually eliminates maintenance and environmental emissions.

Dual Bushings (4A, 4B)

Replaceable alpha sintered silicon carbide bushings ride evenly on the shaft and distribute radial loading over the entire length of the shaft. The

self-aligning design eliminates premature wear caused by bushing misalignment. Internal spiral grooves help flush and lubricate the shaft during operation. A pure PTFE spacer separates the bushings. Optional carbon bushings allows run dry capability.

Shaft (5)

Replaceable premium sintered silicon carbide shaft is shaped to minimize stress concentrations. Shaft is fully supported on both ends for maximum strength.

Barrier (6, 6A, 12)

A precision molded, carbon-filled ETFE liner and external containment shell of woven glass-reinforced vinyl ester make up the barrier assembly, providing optimum chemical and pressure resistance. The nonmetallic design eliminates energy losses due to eddy currents from the magnetic coupling. The barrier contains an alpha sintered silicon carbide rear thrust ring for maximum durability. A fully contained o-ring provides a leak-proof seal.

Clamp Ring (7)

A machined steel clamp ring provides a precise fit between barrier and casing to minimize barrier stress and deflection under pressure for maximum operating reliability. It separates the liquid end from the motor allowing the motor to be removed without opening the liquid end.

Drive Assembly, Motor Adapter, Motor Adapter Flange (8, 9, 10)

Drive assembly and motor adapter are made of high strength ductile iron for added mechanical strength and stiffness. The outer drive is dynamically balanced to ensure smooth operation and reliability. The motor adapter is designed to slide over the outer drive magnet for easy maintenance. An optional bronze bump ring is added to the motor adapter for explosion-proof environments and in ATEX certified models. A machined steel motor adapter flange allows the pump to be mounted to a wide array of NEMA and IEC motors.

UC Series Dimensions

SIDE VIEW

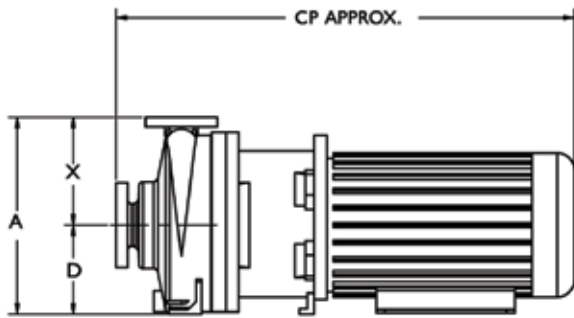

Motor Frame	CP	
	A-Drive inches	B-Drive inches
NEMA		
143-145TC	23-3/4	-
182/184TC	27-5/16	29-1/16
213/215TC	30-1/2	31-1/2
254/256TC	-	36
IEC	A-Drive mm	B-Drive mm
80	581	-
90	617	-
110/112	675	-
132	739	765
160	-	860

FRONT VIEW

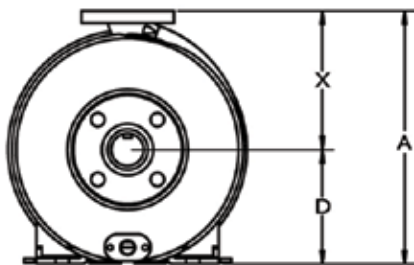

NEMA FRAMES - Dimensions in inches. All frame sizes shown.

Model	Suction Flange	Discharge Flange	D	X	A
UC1516	1-1/2	1	5-1/4	6-1/2	11-3/4
UC326	3	2	5-1/4	6-1/2	11-3/4
UC1518	1-1/2	1	5-1/4	6-1/2	11-3/4

BOTTOM VIEW

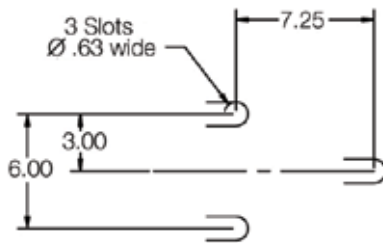

IEC FRAMES - Dimensions in mm. All frame sizes shown except "D".

Model	Suction Flange	Discharge Flange	D*	X	A
UC1516	38	25	134	165	300
UC326	76	50	134	165	300
UC1518	38	25	160	165	300

*Contact manufacturer for further details on 132/160 IEC Dimensions.

SUCTION & DISCHARGE

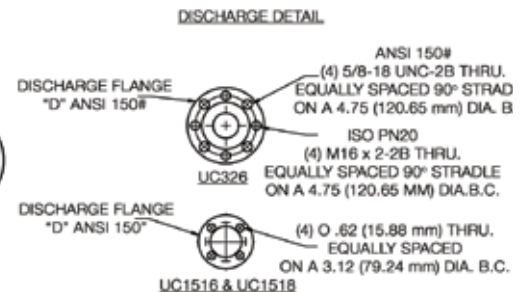
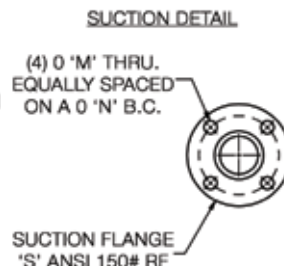
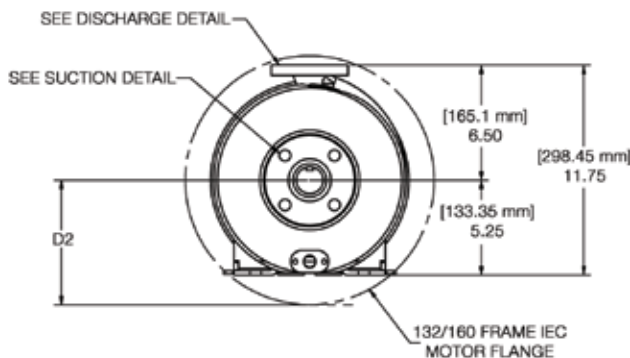

NOTE: Drawings are for reference only. Do not use for construction purposes. Contact FTI for more detailed drawings.

Replaceable Wear Parts



All wear parts are made from highly corrosion resistant materials and are able to withstand repeated use in chemical applications. They are easily field replaceable.

Contact Finish Thompson for more information.

Replaceable Wear Parts:

- Shaft
- O-ring
- Rear Sealing Ring
- Bushings
- Front Thrust Ring
- Impeller Thrust Ring

UC Accessories

Digital Power Monitor



A power monitor is valuable insurance for pumps with silicon carbide bushings which lack run dry ability.

The device is programmed to use the pump's motor as a sensor. It measures the pump motor input power and calculates motor power loss using a unique algorithm. It monitors the power used only by the pump and eliminates losses in the motor. This results in precise motor shaft power measurement.

What does all this mean? Simply that the power monitor almost instantly senses the drop in power when a pump runs dry and quickly shuts the pump down before damage can occur. FTI power monitors are compact, user friendly, and easy to install and operate.

Available in: 3 phase 440-500 VAC; 3 phase 220-240 VAC; 3 phase 380-420 VAC and 3 phase 525-690 VAC

UC with Long-Coupled Bearing Frame

Utilizes pump bearing frame and flex coupling between pump and motor.

- Mounts to any UC Series mag drive
- Allows use of alternative drives such as non-C face, DC, air, pulley or hydraulic
- Flood oil or regreasable bearing configurations
- Rugged ductile iron construction
- Group 1 ASME/ANSI B73.1-1991 dimensional
- 30,000 hours L10 bearing life
- Sight window for oil level



Baseplates

- Fabricated steel or fiberglass
- Extra strong and rigid
- Suitable for grouting



Bronze Bump Ring

When added to the motor adapter, this option provides a non-sparking surface making the pump suitable for applications in hazardous areas. With this option the pump is ATEX certified and meets the requirements of Group II, Category 2 equipment.



UltraChem® - *Extreme* Reliability in
Extreme Chemical Applications



*Having trouble selecting a pump?
Try our handy online pump selector at www.finishthompson.com.*



FINISH THOMPSON INC.

921 Greengarden Road • Erie, PA 16501-1591 U.S.A.
Ph 814-455-4478 • Fax 814-455-8518
Email fti@finishthompson.com • www.finishthompson.com

