



POMPA PER VUOTO LUBRIFICATA AD INIEZIONE D'OLIO OIL INJECTION LUBRICATED VACUUM PUMP

60 PBO - PBOM



Gruppo pompante, in ghisa, accoppiato al motore tramite giunto elastico e ventola centrifuga per il raffreddamento. Serbatoio olio in alluminio con scomparto separazione e recupero aria/olio per l'eliminazione di nebbie d'olio in mandata. Valvola di ritegno in aspirazione. A necessità valvola zavorra gas e base d'appoggio.



Cast-iron pumping unit, coupled to the motor by means of a flexible coupling and centrifugal fan for cooling. Aluminium oil tank with a compartment for separation and recovery of air/oil for eliminating oil mists on the delivery side. Check valve on the suction side. If required, gas ballast valve and supporting base.



SPECIFICHE - SPECIFICATIONS

			50 Hz	60 Hz
Portata	Pumping speed	(Nm ³ /h)	60	72
Vuoto finale (Ass.)	Ult.vacuum (Abs)	(mbar)	10 PBO - 0,5 PBOM	10 PBO - 0,5 PBOM
Esecuzione motore	Motor version	(V) multi tensione - multivolts	Y	380-400-415-440-460-480
			Δ	220-230-240-254-275
		(V) 1 ~ - single phase	230	230
Potenza motore	Motor rating	(Kw) multi tensione - multivolts	1.5	1.5
		(Kw) 1 ~ - single phase	1.5	1.5
Nr.giri	Motor speed	giri/min - rpm	1450	1740
Rumorosità media	Noise level	(dB)	67	67
Peso max.	Max.weight	(Kg)	64	64
Quantità olio	Oil capacity	(Lt.)	3	3

Salvo modifiche tecniche - We reserve the right to alter technical information.

BGS GENERAL S.r.l.

Via ZIBIDO, 3 - 20080 ZIBIDO SAN GIACOMO Mi Italia - Tel. +39.02.90.00.50.69 r.a. - Fax. +39.02.90.00.57.75

E-mail : bigiesse@bigiesse.it - Internet: <http://www.bigiesse.it>



DIMENSIONI - DIMENSIONS

(mm)	
A	600
B	285
C	395
D	210
E	150
F	122
G	165
H	220
K	215
L	120
M	365
N	114
O	100
P	122
R	50
S	30
Øa	1" G
Øm	1" G
Øf	9
X	209
Y	317
W	30

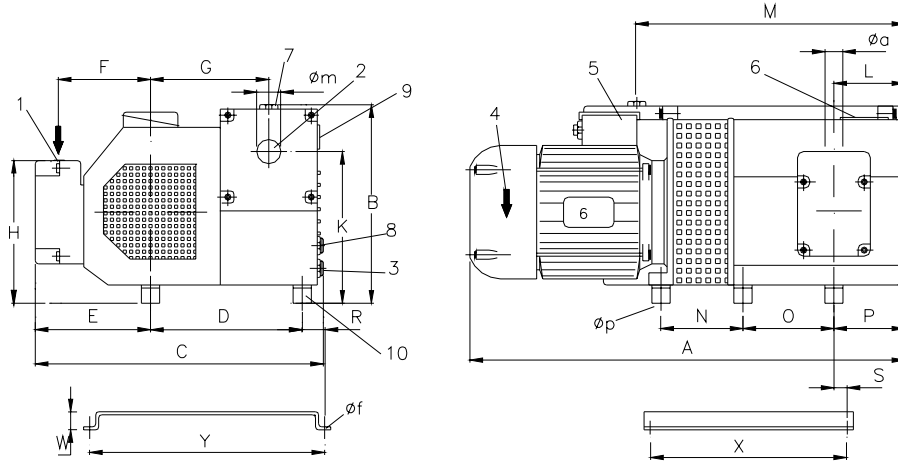

Salvo modifiche tecniche - We reserve the right to alter technical information.

1	Valvola di aspirazione	Suction valve	6	Targhetta dati	Data plate
2	Scarico aria	Exhaust	7	Tappo riempimento olio	Oil filler
3	Scarico olio	Oil drain	8	Spia livello olio	Oil control
4	Freccia senso di marcia	Rotation arrow	9	Targhetta oli consigliati	Oil type plate
5	Morsettiera	Wiring box	10	Piedini	Damper

PRESTAZIONI - PERFORMANCE CURVE

50 HZ / 60 HZ

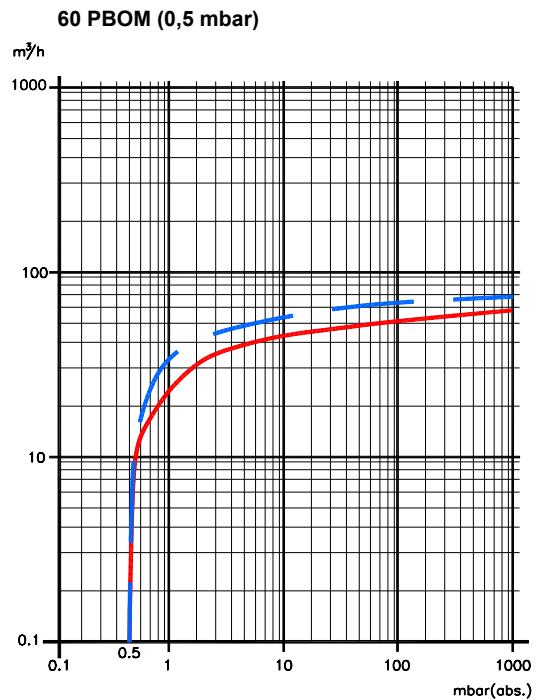
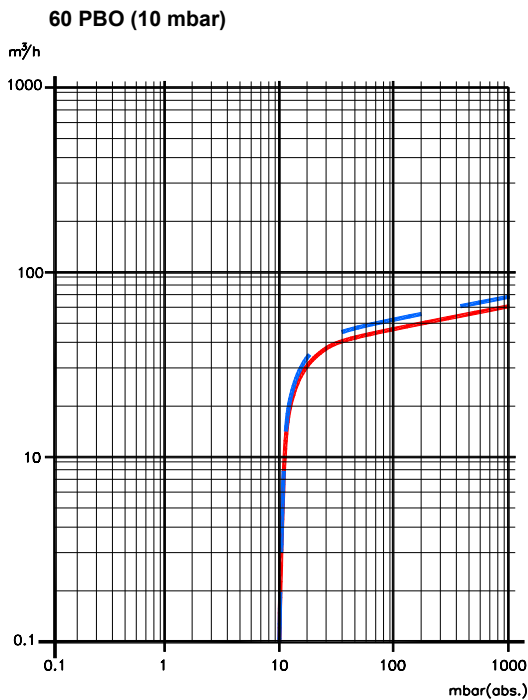

BGS GENERAL S.r.l.

Via ZIBIDO, 3 - 20080 ZIBIDO SAN GIACOMO Mi Italia - Tel. +39.02.90.00.50.69 r.a. - Fax. +39.02.90.00.57.75
 E-mail : bigiesse@bigiesse.it - Internet: <http://www.bigiesse.it>