

A large, stylized green leaf graphic that curves from the top left towards the bottom right, framing the text. The leaf is composed of several overlapping, curved segments in a vibrant green color.

ALBIN PUMP ALP

Instruction manual

Albin Pump ALP Installation

Contents

Important Precautions	2
Principles of Operation	2
Installation Planning	2-3
Pump Test and Installation	3
Before Initial Start-Up	3
Maintenance	3
Troubleshooting	3
Service	
Models ALP09, ALP13, ALP17, ALP25.....	4-5
Models ALP30, ALP45.....	6
Parts List Identification	
Models ALP09, ALP13, ALP17	7
Models ALP25, ALP30, ALP45	8

Limited Warranty

Albin Pump SAS extends to the original purchaser of equipment manufactured by it and bearing its name, a limited one-year warranty from the date of purchase against defects in material or workmanship, provided that the equipment is installed and operated in accordance with the recommendations and instructions of Albin Pump SAS. Albin Pump SAS will repair or replace, at its option, defective parts without charge if such parts are returned with transportation charges prepaid Albin Pump SAS, Z.a.c de Fontgrave, 26130 Montboucher/Jabron, France.

This warranty does not cover:

1. The electric motors (if any), which are covered by the separate warranties of the manufacturers of these components.
2. Normal wear and/or damage caused by or related to abrasion, corrosion, abuse, negligence, accident, faulty installation or tampering in a manner which impairs normal operation.
3. Transportation costs.

This limited warranty is exclusive, and is in lieu of any other warranties (express or implied) including warranty of merchantability or warranty of fitness for a particular purpose and of any non-contractual liabilities including product liabilities based on negligence or strict liability. Every form of liability for direct, special, incidental or consequential damages or loss is expressly excluded and denied.

CAUTION

Important Precautions

To avoid personal injury or pump damage, follow all instructions and safety precautions carefully.

- Don't exceed the manufacturer's recommended RPM or pressure limits.
- Follow all codes and hydraulic recommendations on installation and operation of the pumping system.
- For safety and easier servicing, provide adequate work space around the pump. Allow space to remove the front cover, hose clamps, hose, and drive unit.
- To prevent vibration, mount the pump and motor securely to a rigid, level base.

Principle of Operation

Two rollers, mounted on a rotor, alternately compress a thick-walled hose in a patented concentric guide. As they rotate, they push the liquid in the hose from the suction to the discharge side. The subsequent opening of the hose, after a roller passes, creates a vacuum on the suction side — resulting in continuous pumping.

Installation Planning

Inlet Piping

- Size the inlet line one or two sizes larger than pump suction opening.
- Suction lines should be as short and direct as possible.
- Size the suction line so that the velocity will not exceed 1 – 3 ft/sec.
$$\text{Velocity} = \frac{0.408 \times \text{GPM}}{\text{Pipe I.D.}}$$
- Use flexible hose and/or expansion joints, to absorb vibrations, expansions, or contractions.
- Install an inlet pressure/vacuum gauge on the inlet side of the pump.
- To reduce turbulence and resistance, do not use 90° elbows. If turns are necessary in the suction line use 45° elbows or long sweeping elbows when required.
- Install piping supports where necessary to relieve strain on the inlet line and to minimize vibration.
- In extreme cases, a pulsation dampener may be required to decrease acceleration head.

Discharge Piping

- Size the discharge line to at least the size of the pump inlet connection.
- Between the pump and hard piping, use flexible hose that is long enough to reduce pulsations.
- Install a pressure gauge in the discharge piping.
- In extreme cases, a pulsation dampener may be required to absorb excessive pulsation (caused by high pump speed and long discharge lines).

Albin Pump ALP Installation

Rev Date 11/20/03

Pump Test and Installation

Before you install the pump in the system, set the direction of pump rotation and the position of the pressure rollers:

1. Remove the front cover from the pump (four screws).
2. For easier adjustment, check that the pressure rollers are in the position shown in Fig. 1 (one roller compressing the middle of the hose, and one roller free).

Note: Model ALP30 and ALP45 pumps use a different rotor assembly than the one shown in Fig. 1.

3. Connect the incoming power supply to the motor (refer to the motor manufacturer's instructions).
4. Run the pump and check the direction of rotation ("A" or "B" in Fig. 2). All pumps must rotate in direction "A" (counter-clockwise). To reverse the rotation, exchange two of the three wires that connect the incoming power to the motor.
5. Set the pressure rollers (see "Service: Setting the Roller Pressure"). The roller pressure is not set at the factory, because it must be adjusted to compensate for the size of the inlet and discharge lines and the specific gravity of the fluid being pumped.
6. Reattach the front cover.
7. Install the pump in the system.

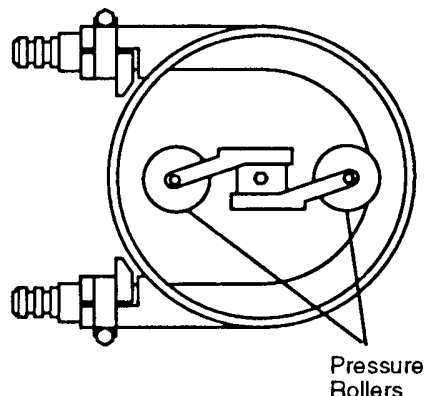

Fig. 1

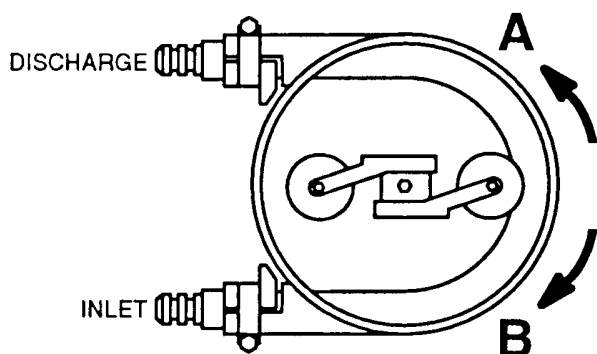

Fig. 2

Before Initial Start-Up

Before you pump fluid through the system, be sure that:

- All shutoff valves are open.
- All connections are tightly secured.
- The hose material is compatible with the fluid being pumped, and the hose design matches the duty cycle and discharge pressures.

Routine Maintenance

Periodically inspect the hose for signs of failure caused by chemical attack, material fatigue, etc.

Check the non-petroleum silicone lubricant on the hose, and reapply if worn off.

Inspect the roller bearings for damage, and replace if necessary (Item No. 11, "Parts List").

Troubleshooting

If the hose fails prematurely, check for:

- Chemical attack. If the hose becomes soft, spongy, or harder than when originally supplied, chemical attack may be the problem.
- Improper hose selection for the fluid being pumped.
- Improper roller setting. If flow fluctuates back and forth or up and down in the discharge line, the rollers may not be adjusted with equal pressure on the hose.

- If the hose fails in area A, shown below, this may occur from

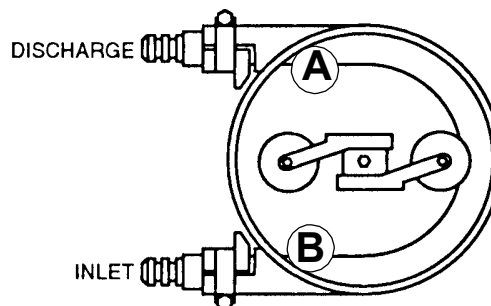

operating the pump at a discharge pressure higher than the hose is rated for, or with a closed discharge line. If the hose fails in area B, this may occur from operating the pump under a higher vacuum or higher inlet pressure than the hose is rated for, or with a closed suction line.

- Line system problems — debris, closed valves, or a clogged or packed line.
- Fluid temperature too high.
- Abrasive material being pumped, or solid size too large.

Service (ALP09, ALP13, ALP17)

Replacing a Worn Hose

Remove Old Hose

1. Turn off and lock out all power to the pump motor.
2. Remove the front cover from the pump (four screws).
3. Position the pressure rollers as shown in Fig. 3.
4. Loosen the screw(s) that secure the mounting bracket of the pressure roller which is compressing the hose. See Fig. 3. To maintain the correct hose compression adjustment, **DO NOT** touch the other roller's mounting bracket.

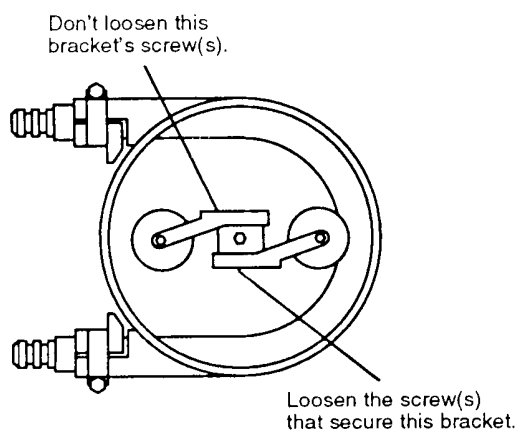

Fig. 3

5. Loosen the hose clamp bolts. See Fig. 4. Remove the hose supports and clamps that secure both ends of the hose.

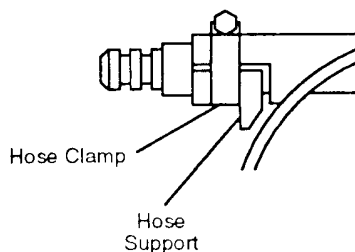

Fig. 4

6. Pull the hose out of the pump casing.
7. Pull the hose connectors from the worn hose. If reusable (when installing the new hose), clean them.
8. Carefully clean the pump casing and the front cover.

Install New Hose

1. Check that you have the correct length of hose:
Model ALP09: 13 in. (330 mm)
Model ALP13: 15 3/8 in. (390 mm)
Model ALP17: 23 1/4 in. (590 mm)
Model ALP25: 33 7/8 in. (860 mm)
2. Install the connectors onto the new hose.
3. Make sure that the pressure rollers are in the same position as before (step 3).
4. Position the bent hose inside the pump casing.
5. Push the upper connector against the end of the pump casing. Install the top hose clamp and secure its bolt.
6. Repeat Step 5 on the lower connection.

Important: On models ALP09 through ALP25, make sure the hose lays completely against the inside of the pump casing.

7. Smear non-petroleum silicone grease on the inner surface of the hose (where the rollers run).
8. Set the roller pressure according to the procedure below (steps 3 – 9 only).

Service (ALP09, ALP13, ALP17)

Setting the Roller Pressure

Note: The pressure setting must be checked when a new hose is installed, because of variations in hose thickness.

1. Remove the front cover from the pump (four screws).
2. Slightly loosen the screw(s) of the mounting bracket of one of the pressure rollers (so that the roller won't compress the hose when the pump is running). See Fig. 5.

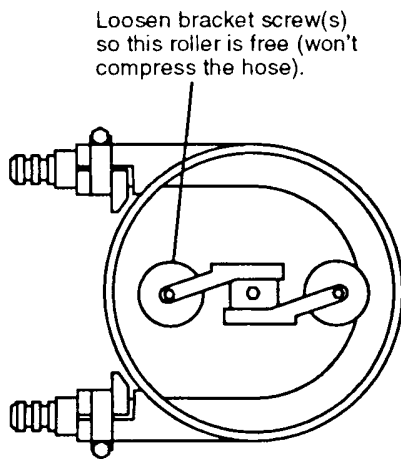

Fig. 5

3. Start the pump. Place the palm of your hand over the suction opening, and check whether the second roller (the one whose bracket is still secured) is compressing the hose enough to create a vacuum. See Fig. 6.

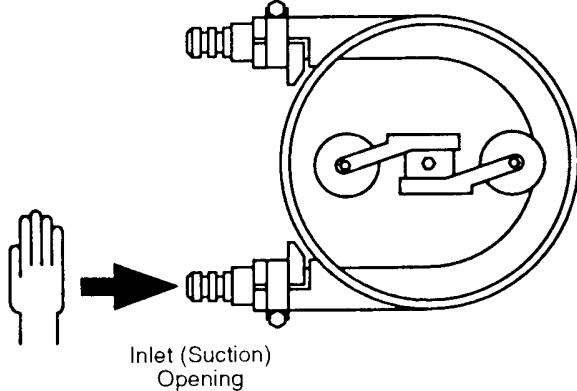

Fig. 6

If there is a vacuum on the first attempt, the roller is set too tight and the hose will be squashed excessively during use. Move the roller's bracket backward (away from the hose) $1/64$ to $1/32$ in. (0.5 to 1.0 mm) and test again.

If, on the contrary, there is no suction at all, move the roller forward (compressing the hose further).

4. Continue testing as in step 3 until the suction seems to be correct, then tighten the screw(s) on the roller's bracket.
5. Turn the rotor a half turn so that the fixed roller (opposite the one you freed in step 2) is riding on the middle of the hose. See Fig. 7.

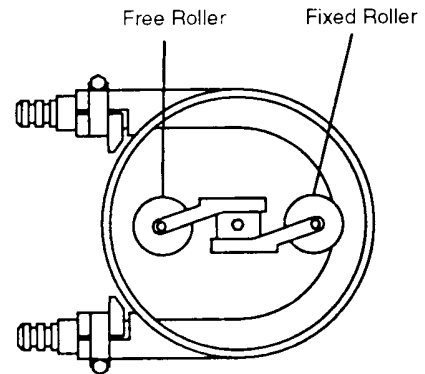

Fig. 7

6. Set the free roller's bracket to the same relative position on the aluminum block as the fixed roller's bracket. See Fig. 8.

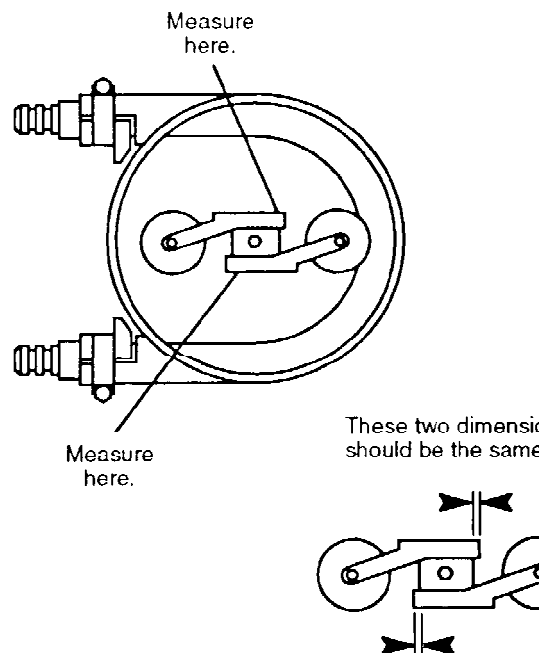

Fig. 8

7. Manually rotate the shaft in either direction, to verify that there is vacuum even if the pump is not running. If there is no vacuum, move the pressure rollers toward the hose $1/64$ in. (0.5 mm).
8. Test the pump in full operation, and readjust as necessary.
9. Reattach the front cover.

Service (ALP25, ALP30, ALP45)

Replacing a Worn Hose

Remove Old Hose

1. Turn off and lock out all power to the pump motor.
2. Remove the front cover from the pump (four screws).
3. Position the rotor as shown in Fig. 9.
4. Remove the roller holder (two screws) which is not compressing the hose. Also remove any shims under it. Turn the rotor 180° as in Fig. 10.

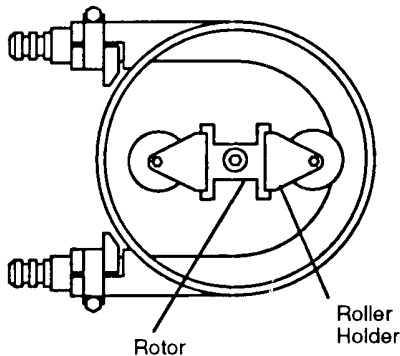

Fig. 9

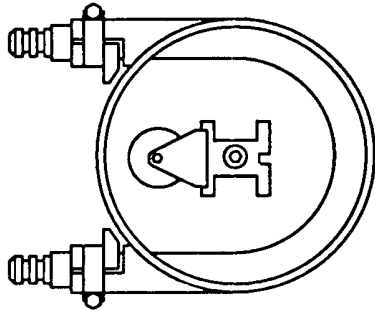

Fig. 10

5. See Fig. 11. Loosen the clamp bolts. Remove the hose supports and clamps that secure both ends of the hose.

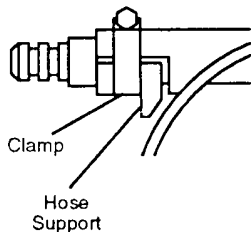

Fig. 11

6. Pull the hose out of the pump casing.
7. Pull the hose connectors from the worn hose. If reusable, clean them.
8. Carefully clean the pump casing and the front cover.

Install New Hose

1. Check that you have the correct length of hose:
Model ALP30: 45 1/4 in. (1150 mm)
Model ALP45: 57 1/4 in. (1455 mm)
2. Install the connectors onto the new hose.
3. Position the bent hose inside the pump casing.
4. Push the upper connector against the end of the pump casing. Install the top clamp and secure its bolt.
5. Repeat Step 4 on the lower connection.

Important: On models ALP30 and ALP45, allow a 1-1.5 mm gap between the hose and the inside of the pump casing at Point A as shown in the illustration at right.

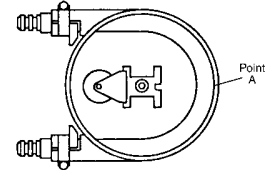

6. Smear non-petroleum silicone grease on the inner surface of the hose (where the rollers run).
7. Turn the rotor 180°. Reinstall the roller holder without shims.
8. Set the roller pressure according to the procedure below (steps 3 – 7 only).

Setting the Roller Pressure

Note: The pressure setting must be checked when a new hose is installed, because of variations in hose thickness.

1. Remove the front cover from the pump (four screws).

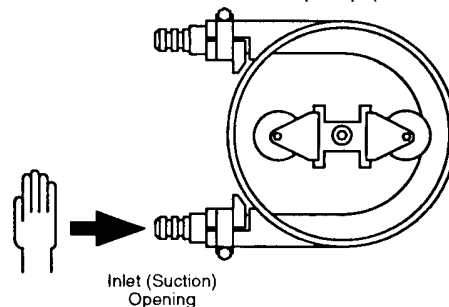

2. Remove any shims under the two roller holders.
3. Be sure the bolts securing the roller holders are locked.
4. Start the pump. Place the palm of your hand over the suction opening, and check whether the roller is compressing the hose enough to create a vacuum. See Fig. 12.

If there is a vacuum on the first attempt, the rollers are set too tight and the hose will be squashed excessively during use. Gradually add 0.5 mm (.02 in.) shims under one of the rollers and repeat the test until the suction seems to be correct. **Do not install more than four shims** under each roller.

5. Add the same number of shims under the other roller.
6. Test the pump in full operation, and readjust as necessary.
7. Reattach the front cover.

Parts List (ALP09, ALP13, ALP17)

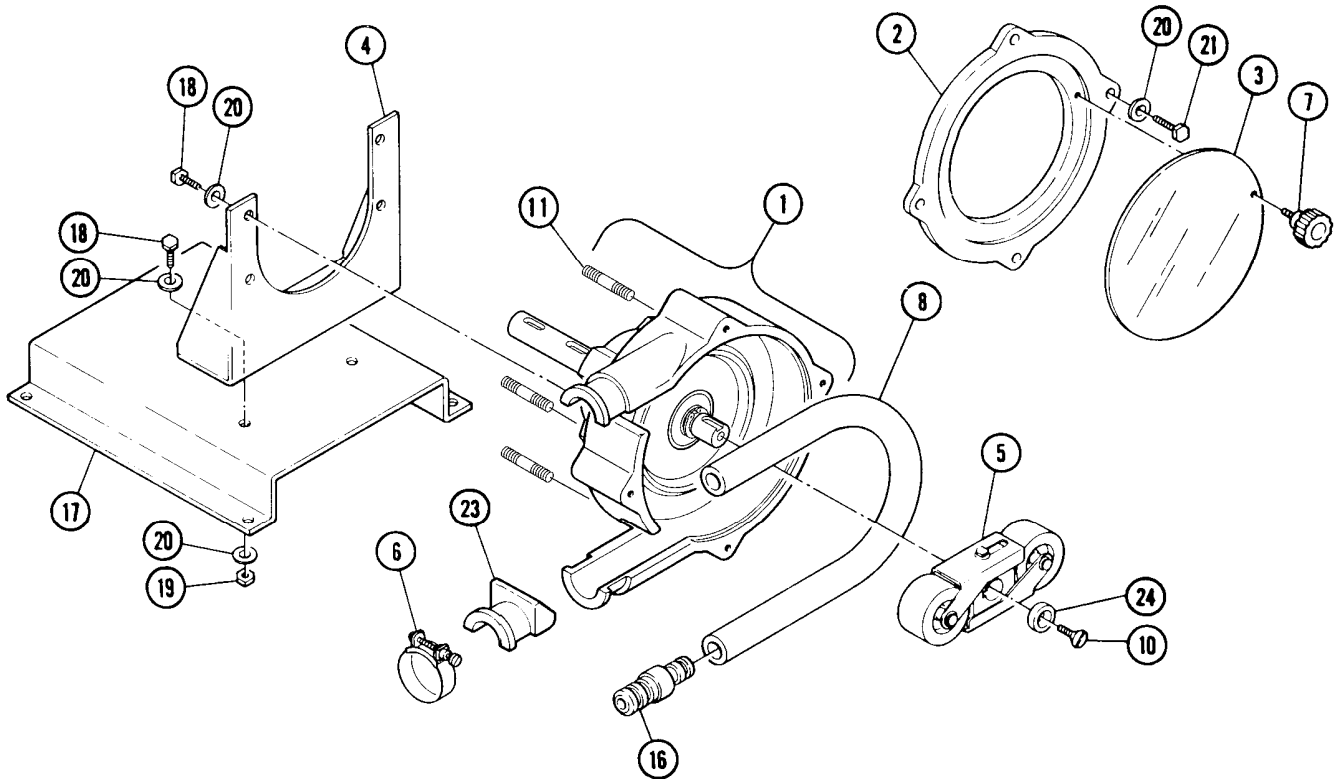

Ref. No.	Description	Qty, per Pump	Ref. No.	Description	Qty, per Pump
1	Casing	1	11	Stud	4
2	Cover, front.....	1	16	Connector, hose	1
3	Window, cover	1	17	Base	1
4	Bracket, mounting	1	18	Bolt, mounting	6
5	Roller assembly	1	19	Nut	6
6	Clamp, hose	2	20	Washer	16
7	Screw, cover	1 or 2	21	Bolt, cover	4
8	Hose	1	22	Key, roller assembly (not shown)	1
9	Key, motor (non shown)	2	23	Support, hose	2
10	Screw, roller	1	24	Washer, roller mounting	1

Parts List (ALP25, ALP30, ALP45)

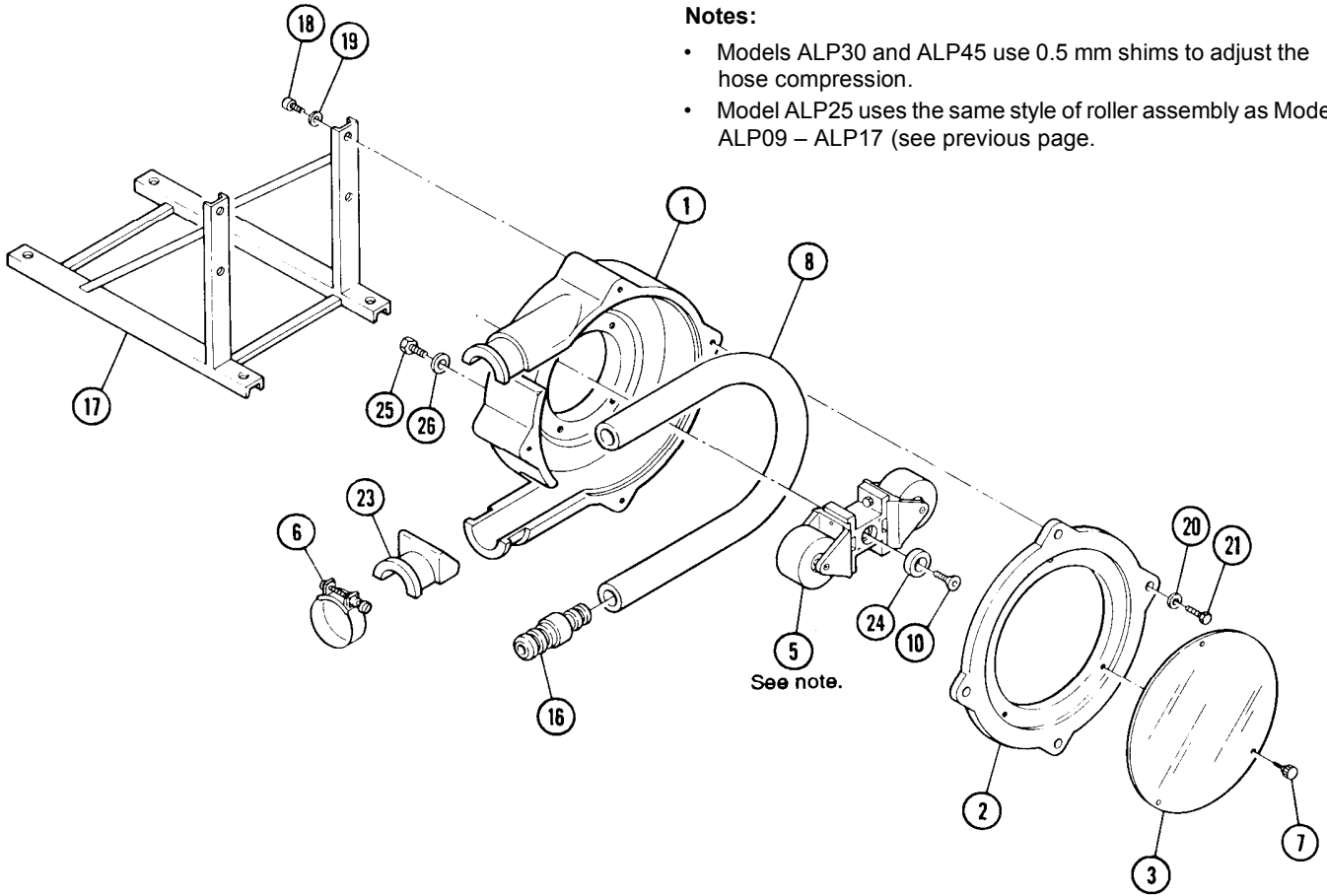

Notes:

- Models ALP30 and ALP45 use 0.5 mm shims to adjust the hose compression.
- Model ALP25 uses the same style of roller assembly as Models ALP09 – ALP17 (see previous page).

Ref. No.	Description	Qty, per Pump
1	Casing	1
2	Cover, front.....	1
3	Window, cover	1
5	Roller assembly	1
6	Clamp, hose	4
7	Screw, cover.....	2 or 3
8	Hose	1
10	Screw, roller	1

Ref. No.	Description	Qty, per Pump
16	Connector, hose	1
17	Base	1
18	Bolt, mounting	4
19	Washer	4
20	Washer	4
21	Bolt, cover	4
23	Support, hose	2
24	Washer, roller mounting	1
25	Bolt	4
26	Washer	
—	Shim, 0.5 mm (.02 in.)	8 max

Albin Pump SAS

Z.A de Fontgrave
26740 Montboucher
France

Tel +33 (0) 4 75 90 92 92

Fax +33 (0) 4 75 90 92 40

info@albinpump.fr

www.albinpump.fr

