

# Husky<sup>®</sup> 1050 Air-Operated Diaphragm Pump

313435G  
ENG

**1-inch pump with modular air valve for fluid transfer applications.  
For professional use only.**

**See page 3 for model information, including approvals.**

125 psi (0.86 MPa, 8.6 bar) Maximum Fluid Working Pressure  
125 psi (0.86 MPa, 8.6 bar) Maximum Air Input Pressure

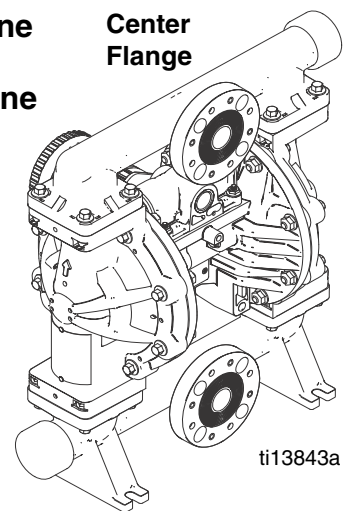


**Important Safety Instructions**

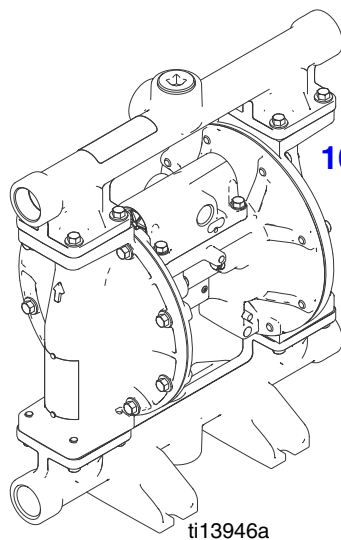
Read all warnings and instructions in this manual.  
Save these instructions.

- 1050P** Polypropylene
- 1050C** Conductive Polypropylene
- 1050F** PVDF

Center Flange



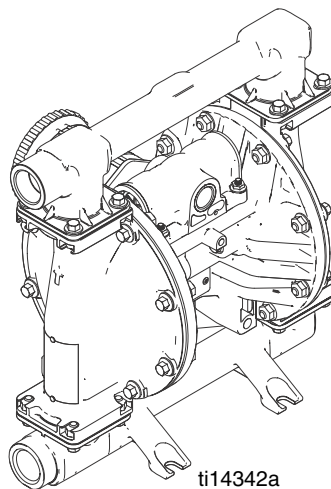
ti13843a



**1050A** Aluminum

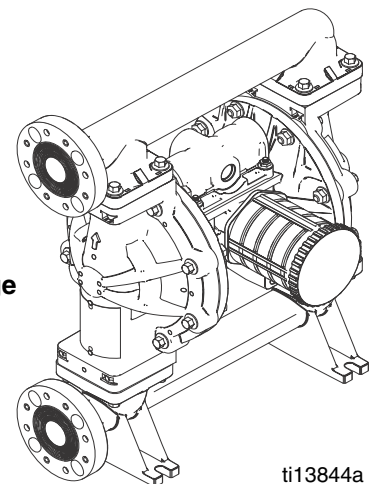
ti13946a

**1050S** Stainless Steel  
**1050H** Hastelloy



ti14342a

End Flange



ti13844a

# Contents

<b>Related Manuals</b> .....	<b>2</b>	<b>Parts</b> .....	<b>16</b>
<b>Pump Matrix</b> .....	<b>3</b>	Parts/Kits Quick Reference .....	17
ATEX Certifications .....	3	Center Section .....	18
<b>Warnings</b> .....	<b>4</b>	Air Valve and Data Monitoring .....	20
<b>Troubleshooting</b> .....	<b>6</b>	Fluid Covers and Manifolds .....	24
<b>Repair</b> .....	<b>8</b>	Seats .....	26
Pressure Relief Procedure .....	8	Check Balls .....	26
Repair or Replace Air Valve .....	8	Diaphragms .....	27
DataTrak .....	11	Manifold O-rings .....	29
Check Valve Repair .....	11	DataTrak .....	29
Diaphragms and Center Section .....	12	Accessories .....	29
Torque Instructions .....	15	<b>Technical Data</b> .....	<b>30</b>
		<b>Graco Standard Husky Pump Warranty</b> .....	<b>32</b>
		<b>Graco Information</b> .....	<b>32</b>

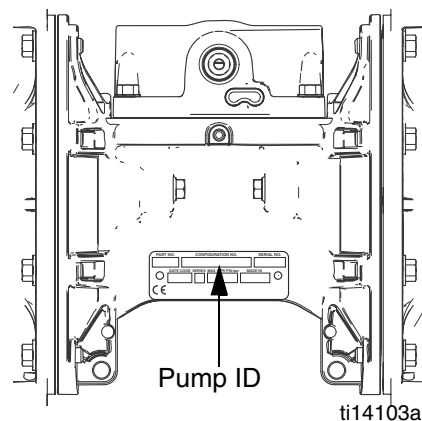
## Related Manuals

Manual	Description
312877	Husky 1050 Air-Operated Diaphragm Pump, Operation
313597	Husky 1050A UL-Listed Diaphragm Pump, Operation
313598	Husky 1050A CSA-Certified Diaphragm Pump, Operation
313840	DataTrak, Instructions/Parts
406824	Pulse Count Kits, Instructions
406825	Reed Switch with Solenoid Kits, Instructions
406826	Torque Instructions (Manifolds and Fluid Covers)

# Pump Matrix

Check the identification plate (ID) for the 20-digit part number of your pump. Use the following matrix to define the components of your pump. For example, pump number **1050A-A01AA1SSBNBNPT** represents a Husky 1 inch, 50 gpm aluminum pump (**1050A**), with aluminum center section (**A01**), a standard air valve (**A**), aluminum fluid covers (**A**) and manifolds with standard ports in inches (**1**). The pump has stainless steel seats (**SS**), buna-N check balls (**BN**), buna-N diaphragms (**BN**), and PTFE manifold o-rings (**PT**).

**NOTE:** Available options for seats, check balls, diaphragms, and seals vary based on pump model (**1050A-1050S**). To build a pump, use the selector tool at [www.graco.com](http://www.graco.com) or speak with your distributor.



ti14103a

Pump Model (1 inch ports, 50 gpm)	Center Section and Air Valve Material	Air Valve/Monitoring	Fluid Covers and Manifolds
<b>1050A</b> ★ Aluminum	Aluminum	<b>A01A</b> Standard	<b>A1</b> Aluminum, standard ports, inch
		<b>A01B</b> Pulse Count✳	<b>A2</b> Aluminum, standard ports, metric
		<b>A01C</b> DataTrak✳	<b>C1</b> Conductive polypropylene, center flange
		<b>A01D</b> Remote	<b>C2</b> Conductive polypropylene, end flange
<b>1050C</b> ★ Conductive Polypropylene	Conductive Polypropylene	<b>C01A</b> Standard	<b>F1</b> PVDF, center flange
		<b>C01B</b> Pulse Count✳	<b>F2</b> PVDF, end flange
		<b>C01C</b> DataTrak✳	<b>H1</b> Hastelloy, standard ports, inch
		<b>C01D</b> Remote	<b>H2</b> Hastelloy, standard ports, metric
<b>1050F</b> PVDF	Polypropylene	<b>P01A</b> Standard	<b>P1</b> Polypropylene, center flange
<b>1050H</b> ‡ Hastelloy		<b>P01B</b> Pulse Count✳	<b>P2</b> Polypropylene, end flange
<b>1050P</b> Polypropylene		<b>P01C</b> DataTrak✳	<b>S1</b> Stainless steel, standard ports, inch
<b>1050S</b> ‡ Stainless Steel		<b>P01D</b> Remote	<b>S2</b> Stainless steel, standard ports, metric
★, ‡, or ✳: See <b>ATEX Certifications</b> below.			

Check Valve Seats		Check Valve Balls		Diaphragm		Manifold O-Rings	
<b>AC</b> Acetal	<b>AC</b> Acetal	<b>BN</b> Buna-N	<b>BN</b> Buna-N	<b>CO</b> Polychloroprene Overmolded	<b>CO</b> Polychloroprene Overmolded	<b>—</b> None	<b>PT</b> PTFE
<b>AL</b> Aluminum	<b>BN</b> Buna-N	<b>CR</b> Polychloroprene Standard	<b>CR</b> Polychloroprene Standard	<b>FK</b> FKM Fluoroelastomer	<b>FK</b> FKM Fluoroelastomer		
<b>BN</b> Buna-N	<b>CR</b> Polychloroprene Standard	<b>CW</b> Polychloroprene Weighted	<b>CW</b> Polychloroprene Weighted	<b>GE</b> Geolast	<b>GE</b> Geolast		
<b>FK</b> FKM Fluoroelastomer	<b>CW</b> Polychloroprene Weighted	<b>FK</b> FKM Fluoroelastomer	<b>FK</b> FKM Fluoroelastomer	<b>PO</b> PTFE/EPDM Overmolded	<b>PO</b> PTFE/EPDM Overmolded		
<b>GE</b> Geolast®	<b>FK</b> FKM Fluoroelastomer	<b>GE</b> Geolast	<b>GE</b> Geolast	<b>PT</b> PTFE/EPDM Two-Piece	<b>PT</b> PTFE/EPDM Two-Piece		
<b>PP</b> Polypropylene	<b>GE</b> Geolast	<b>PT</b> PTFE	<b>PT</b> PTFE	<b>SP</b> Santoprene	<b>SP</b> Santoprene		
<b>PV</b> PVDF	<b>PT</b> PTFE	<b>SP</b> Santoprene	<b>SP</b> Santoprene	<b>TP</b> TPE	<b>TP</b> TPE		
<b>SP</b> Santoprene®	<b>SP</b> Santoprene	<b>SS</b> 316 Stainless Steel	<b>SS</b> 316 Stainless Steel				
<b>SS</b> 316 Stainless Steel	<b>SS</b> 316 Stainless Steel	<b>TP</b> TPE	<b>TP</b> TPE				
<b>TP</b> TPE	<b>TP</b> TPE						

## ATEX Certifications

★ All **1050A** (Aluminum) and **1050C** (Conductive Polypropylene) pumps are certified:



‡ **1050S** (Stainless Steel) and **1050H** (Hastelloy) pumps with aluminum or conductive polypropylene centers are certified:






✳ **DataTrak** and **Pulse Count** are certified:










EEx ia IIA T3  
Nemko  
06ATEX1124

# Warnings

The following warnings are for the setup, use, grounding, maintenance, and repair of this equipment. The exclamation point symbol alerts you to a general warning and the hazard symbol refers to procedure-specific risk. Refer back to these warnings. Additional, product-specific warnings may be found throughout the body of this manual where applicable.

 <b>WARNING</b>	
	<p><b>FIRE AND EXPLOSION HAZARD</b></p> <p>Flammable fumes, such as solvent and paint fumes, in <b>work area</b> can ignite or explode. To help prevent fire and explosion:</p> <ul style="list-style-type: none"> <li>• Use equipment only in well ventilated area.</li> <li>• Eliminate all ignition sources; such as pilot lights, cigarettes, portable electric lamps, and plastic drop cloths (potential static arc).</li> <li>• Keep work area free of debris, including solvent, rags and gasoline.</li> <li>• Do not plug or unplug power cords, or turn power or light switches on or off when flammable fumes are present.</li> <li>• Ground all equipment in the work area. See <b>Grounding</b> instructions.</li> <li>• Use only grounded hoses.</li> <li>• Hold gun firmly to side of grounded pail when triggering into pail.</li> <li>• If there is static sparking or you feel a shock, <b>stop operation immediately</b>. Do not use equipment until you identify and correct the problem.</li> <li>• Keep a working fire extinguisher in the work area.</li> </ul> <p>Static charge may build up on plastic parts during cleaning and could discharge and ignite flammable materials and gases. To help prevent fire and explosion:</p> <ul style="list-style-type: none"> <li>• Clean plastic parts in a well ventilated area.</li> <li>• Do not clean with a dry cloth.</li> </ul>
	<p><b>EQUIPMENT MISUSE HAZARD</b></p> <p>Misuse can cause death or serious injury.</p> <ul style="list-style-type: none"> <li>• Do not operate the unit when fatigued or under the influence of drugs or alcohol.</li> <li>• Do not exceed the maximum working pressure or temperature rating of the lowest rated system component. See <b>Technical Data</b> in all equipment manuals.</li> <li>• Use fluids and solvents that are compatible with equipment wetted parts. See <b>Technical Data</b> in all equipment manuals. Read fluid and solvent manufacturer's warnings. For complete information about your material, request MSDS from distributor or retailer.</li> <li>• Do not leave the work area while equipment is energized or under pressure. Turn off all equipment and follow the <b>Pressure Relief Procedure</b> in this manual when equipment is not in use.</li> <li>• Check equipment daily. Repair or replace worn or damaged parts immediately with genuine manufacturer's replacement parts only.</li> <li>• Do not alter or modify equipment.</li> <li>• Use equipment only for its intended purpose. Call your distributor for information.</li> <li>• Route hoses and cables away from traffic areas, sharp edges, moving parts, and hot surfaces.</li> <li>• Do not kink or over bend hoses or use hoses to pull equipment.</li> <li>• Keep children and animals away from work area.</li> <li>• Comply with all applicable safety regulations.</li> </ul>

 <b>WARNING</b>	
	<p><b>PRESSURIZED EQUIPMENT HAZARD</b></p> <p>Fluid from the gun/dispense valve, leaks, or ruptured components can splash in the eyes or on skin and cause serious injury.</p> <ul style="list-style-type: none"> <li>• Follow <b>Pressure Relief Procedure</b> in this manual, when you stop spraying and before cleaning, checking, or servicing equipment.</li> <li>• Tighten all fluid connections before operating the equipment.</li> <li>• Check hoses, tubes, and couplings daily. Replace worn or damaged parts immediately.</li> </ul>
	<p><b>PRESSURIZED ALUMINUM PARTS HAZARD</b></p> <p>Use of fluids that are incompatible with aluminum in pressurized equipment can cause serious chemical reaction and equipment rupture. Failure to follow this warning can result in death, serious injury, or property damage.</p> <ul style="list-style-type: none"> <li>• Do not use 1,1,1-trichloroethane, methylene chloride, other halogenated hydrocarbon solvents or fluids containing such solvents.</li> <li>• Many other fluids may contain chemicals that can react with aluminum. Contact your material supplier for compatibility.</li> </ul>
	<p><b>PLASTIC PARTS CLEANING SOLVENT HAZARD</b></p> <p>Use only compatible water-based solvents to clean plastic structural or pressure-containing parts. Many solvents can degrade plastic parts and cause them to fail, which could cause serious injury or property damage. See <b>Technical Data</b> in this and all other equipment instruction manuals. Read fluid and solvent manufacturer's warnings.</p>
	<p><b>TOXIC FLUID OR FUMES HAZARD</b></p> <p>Toxic fluids or fumes can cause serious injury or death if splashed in the eyes or on skin, inhaled, or swallowed.</p> <ul style="list-style-type: none"> <li>• Read MSDS's to know the specific hazards of the fluids you are using.</li> <li>• Route exhaust away from work area. If diaphragm ruptures, fluid may be exhausted with air.</li> <li>• Store hazardous fluid in approved containers, and dispose of it according to applicable guidelines.</li> <li>• Always wear impervious gloves when spraying or cleaning equipment.</li> </ul>
	<p><b>BURN HAZARD</b></p> <p>Equipment surfaces and fluid that's heated can become very hot during operation. To avoid severe burns:</p> <ul style="list-style-type: none"> <li>• Do not touch hot fluid or equipment.</li> <li>• Wait until equipment/fluid has cooled completely.</li> </ul>
	<p><b>PERSONAL PROTECTIVE EQUIPMENT</b></p> <p>You must wear appropriate protective equipment when operating, servicing, or when in the operating area of the equipment to help protect you from serious injury, including eye injury, inhalation of toxic fumes, burns, and hearing loss. This equipment includes but is not limited to:</p> <ul style="list-style-type: none"> <li>• Clothing and respirator as recommended by the fluid and solvent manufacturer</li> <li>• Protective eyewear, gloves, and hearing protection.</li> </ul>

# Troubleshooting



Problem	Cause	Solution
Pump cycles but will not prime.	Check valve ball severely worn or wedged in seat or manifold.	Replace ball and seat. See page 11.
	Seat severely worn.	Replace ball and seat. See page 11.
	Outlet or inlet clogged.	Unclog.
	Inlet or outlet valve closed.	Open.
	Inlet fittings or manifolds loose.	Tighten.
	Manifold o-rings damaged.	Replace o-rings. See page 11.
Pump cycles at stall or fails to hold pressure at stall.	Worn check valve balls, seats, or o-rings.	Replace. See page 26.
Pump will not cycle, or cycles once and stops.	Air valve is stuck or dirty.	Disassemble and clean air valve. See page 9. Use filtered air.
	Check valve ball severely worn and wedged in seat or manifold.	Replace ball and seat. See page 11.
	Pilot valve worn, damaged, or plugged.	Replace pilot valve. See page 12.
	Air valve gasket damaged.	Replace gasket. See page 8.
	Check valve ball is wedged into seat due to overpressurization.	Install pressure relief kit. See <b>Accessories</b> , page 29.
	Dispensing valve clogged.	Relieve pressure and clear valve.
	Air tubing is plugged (remote air control models).	Clear tube.
Pump operates erratically.	Clogged suction line.	Inspect; clear.
	Sticky or leaking check valve balls.	Clean or replace. See page 11.
	Diaphragm (and backup) ruptured.	Replace. See page 12.
	Restricted exhaust.	Remove restriction.
	Pilot valves damaged or worn.	Replace pilot valves. See page 12.
	Air valve damaged.	Replace air valve. See page 8.
	Air valve gasket damaged.	Replace air valve gasket. See page 8.
	Air supply erratic.	Repair air supply.
Exhaust muffler icing.	Use drier air supply or use low ice muffler (Graco part 102656).	

<b>Problem</b>	<b>Cause</b>	<b>Solution</b>
Air bubbles in fluid.	Suction line is loose.	Tighten.
	Diaphragm (and backup) ruptured.	Replace. See page 12.
	Loose manifolds, damaged seats or manifold o-rings.	Tighten manifold bolts or replace seats or o-rings. See page 11.
	Diaphragm shaft bolt o-ring damaged.	Replace o-ring.
	Pump cavitation.	Reduce pump speed or suction lift.
	Loose diaphragm shaft bolt.	Tighten.
Exhaust air contains fluid being pumped.	Diaphragm (and backup) ruptured.	Replace. See page 12.
	Loose diaphragm shaft bolt.	Tighten or replace. See page 12.
	Diaphragm shaft bolt o-ring damaged.	Replace o-ring. See page 12.
Moisture in exhaust air.	High inlet air humidity.	Use drier air supply.
Pump exhausts excessive air at stall.	Worn air valve cup or plate.	Replace cup and plate. See page 9.
	Damaged air valve gasket.	Replace gasket. See page 8.
	Damaged pilot valve.	Replace pilot valves. See page 12.
	Worn shaft seals or bearings.	Replace shaft seals or bearings. See page 12.
	Air tubing is damaged or loose (remote air control models).	Replace tubing or secure connection.
	Remote air pressure is higher than pump air pressure (remote air control models).	Regulate remote pilot air pressure to be equal to or less than main air.
Pump leaks air externally.	Air valve or fluid cover screws loose.	Tighten.
	Diaphragm damaged.	Replace diaphragm. See page 12.
	Air valve gasket damaged.	Replace gasket. See page 8.
	Remote air pressure is higher than pump air pressure (remote air control models).	Regulate remote pilot air pressure to be equal to or less than main air.
Pump leaks fluid externally from joints.	Loose manifold screws or fluid cover screws.	Tighten manifold screws or fluid cover screws. See page 15.
	Manifold o-rings worn out.	Replace o-rings. See page 11.
Pump leaks fluid externally through manifold or fluid cover.	Excessive pump speed or inlet starvation.	Replace manifold and reduce pump speed or improve pump feed.

# Repair

## Pressure Relief Procedure

<p>Trapped air can cause the pump to cycle unexpectedly, which could result in serious injury from splashing.</p>						

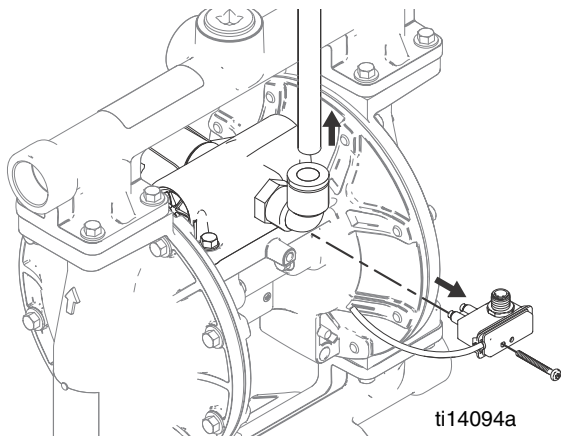
1. Shut off the air supply to the pump.
2. Open the dispensing valve, if used.
3. Open the fluid drain valve to relieve fluid pressure. Have a container ready to catch the drainage.

## Repair or Replace Air Valve

--	--	--	--	--	--	--

### Replace Complete Air Valve

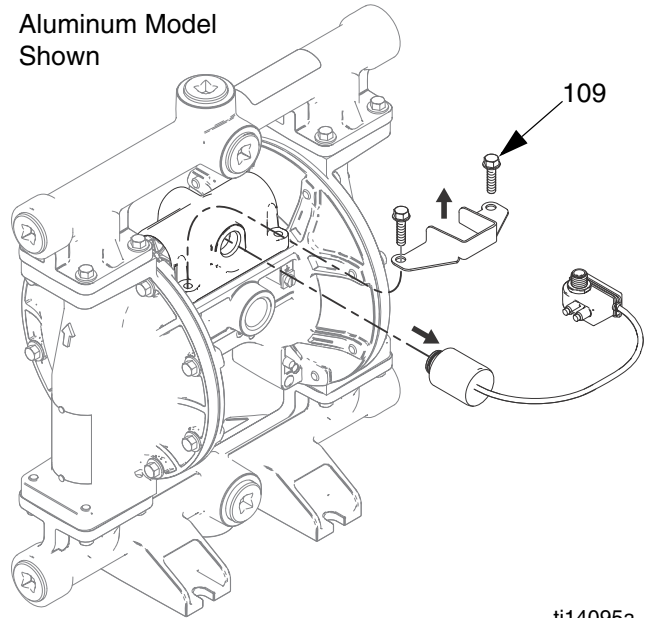
1. Stop the pump. Relieve the pressure. See **Pressure Relief Procedure** in previous section.
2. Disconnect the air line to the motor.
3. **For motors with Pulse Count or DataTrak:** Remove screw to disconnect the reed switch assembly from the air valve.



**FIG. 1. Reed switch assembly and air line removal**

4. **For motors with DataTrak:** Remove two screws and the solenoid bracket. Pull the solenoid out of the air valve.

Aluminum Model Shown



ti14095a

**FIG. 2. Solenoid removal**

5. Remove screws (109, metal pumps) or nuts (112, plastic pumps). Remove the air valve and gasket (108).
6. To repair the air valve, go to **Disassemble the Air Valve**, step 1, in next section. To install a replacement air valve, continue with step 7.
7. Align the new air valve gasket (108) on the center housing, then attach the air valve. See **Torque Instructions**, page 15.
8. **For motors with DataTrak:** Remember to reattach the solenoid bracket and the solenoid.
9. **For motors with Pulse Count or DataTrak:** Use screw to attach the reed switch assembly to the new air valve. Reconnect cable.
10. Reconnect the air line to the motor.



## Replace Seals or Rebuild Air Valve

**NOTE:** Repair kits are available. See page 21 to order the correct kit(s) for your pump. Air Valve Seal Kit parts are marked with a †. Air Valve Repair Kit parts are marked with a ◆. Air Valve End Cap Kit parts are marked with a ⌘.

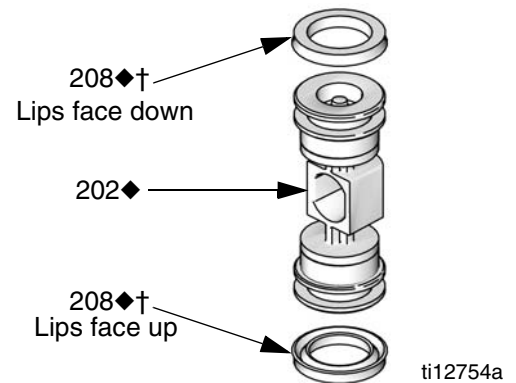
### Disassemble the Air Valve

1. Perform steps 1-5 under **Replace Complete Air Valve**, page 8.
2. See FIG. 4. Use a Torx screwdriver (T8 for aluminum centers, T9 for plastic centers) to remove two screws (209). Remove the valve plate (205), cup (212), spring (211), and detent assembly (203).
3. See FIG. 4. Remove the retaining ring (210) from each end of the air valve. Use the piston (202) to push the end caps (207, 217) out of the ends. Remove end cap o-rings (206). If pump model is equipped with a runaway protection solenoid, also remove the solenoid release button (218) and o-ring (219).
4. Remove the u-cup seals (208) from each end of the piston (202), then remove the piston. Remove the detent cam (204) from the air valve housing (201).

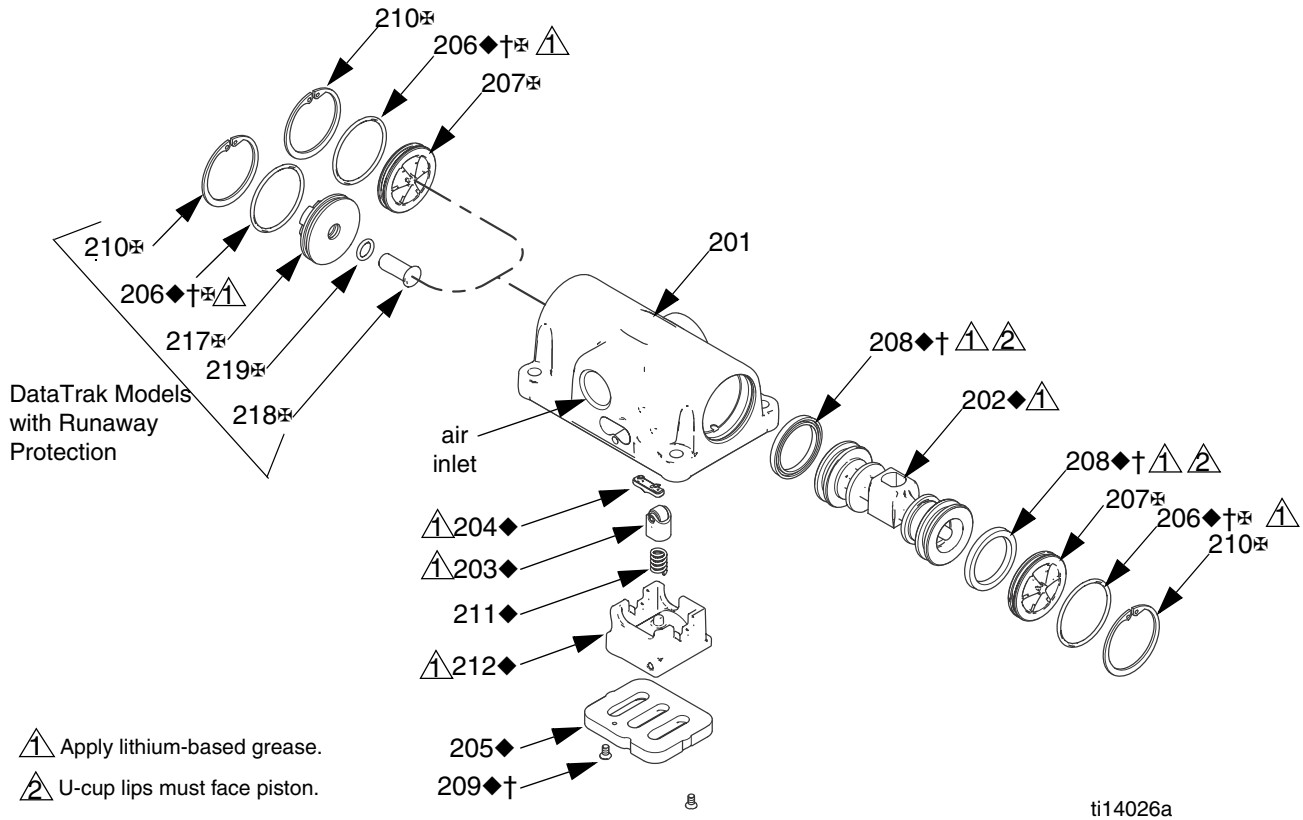
### Reassemble the Air Valve

**NOTE:** Apply lithium-based grease whenever instructed to grease.

1. Use all parts in the repair kits. Clean other parts and inspect for damage. Replace as needed.
2. Grease the detent cam (204) and install into housing (201).
3. Grease the u-cups (208) and install on the piston with lips facing toward the center of the piston.

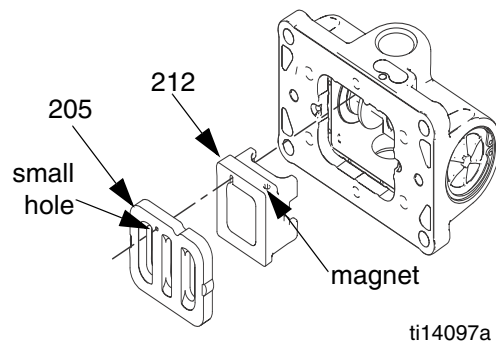


**FIG. 3. Air valve u-cup installation**



**Fig. 4. Air valve assembly**

4. Grease both ends of the piston (202) and install it in the housing (201), with the flat side toward the cup (212). Be careful not to tear u-cups (208) when sliding piston into housing.
5. **Standard or Pulse Count models (no runaway protection solenoid):** Grease new o-rings (206) and install on the end caps (207). Install the end caps into the housing.  
**DataTrak models (with runaway protection solenoid):** Orient the air valve so the air inlet faces forward. Grease and install new o-ring (206) on right-side end cap (207). Grease and install new o-ring (206) and the solenoid release button (218) and o-ring (219) on left-side end cap (217). Install the end caps into the housing.
6. Install a retaining ring (210) on each end to hold end caps in place.
7. Grease and install the detent assembly (203) into the piston. Install the spring (211). Grease the side of the air valve cup (212) that will contact the valve plate (205). Install the air valve cup (212). Align the small round magnet with the air inlet.
8. Install the valve plate (205). Align the small hole in the plate with the air inlet. Tighten the screws (209) to hold it in place.



**Fig. 5. Air valve cup and plate installation**

## DataTrak

**NOTE:** See DataTrak manual, 313840, for all DataTrak service and repair information.

## Check Valve Repair



**NOTE:** Kits are available for new check valve balls and seats in a range of materials. See page 26 to order kits in the material(s) desired. An o-ring kit and fastener kits also are available.

**NOTE:** To ensure proper seating of the check balls, always replace the seats when replacing the balls. Also, on models with manifold o-rings, replace the o-rings.

### Disassembly

1. Follow the **Pressure Relief Procedure** on page 8. Disconnect all hoses.
2. Remove the pump from its mounting.

**NOTE:** For plastic pumps (1050P, 1050C, and 1050F), use hand tools only until thread-locking adhesive patch releases.

3. Use a 10 mm socket wrench to remove the outlet manifold fasteners (6). See FIG. 6.
4. Remove the o-rings (12, *not used on some models*), seats (10), and balls (11).
5. Turn the pump over and remove the inlet manifold. Remove the o-rings (12, *not used on some models*), seats (10), and balls (11).

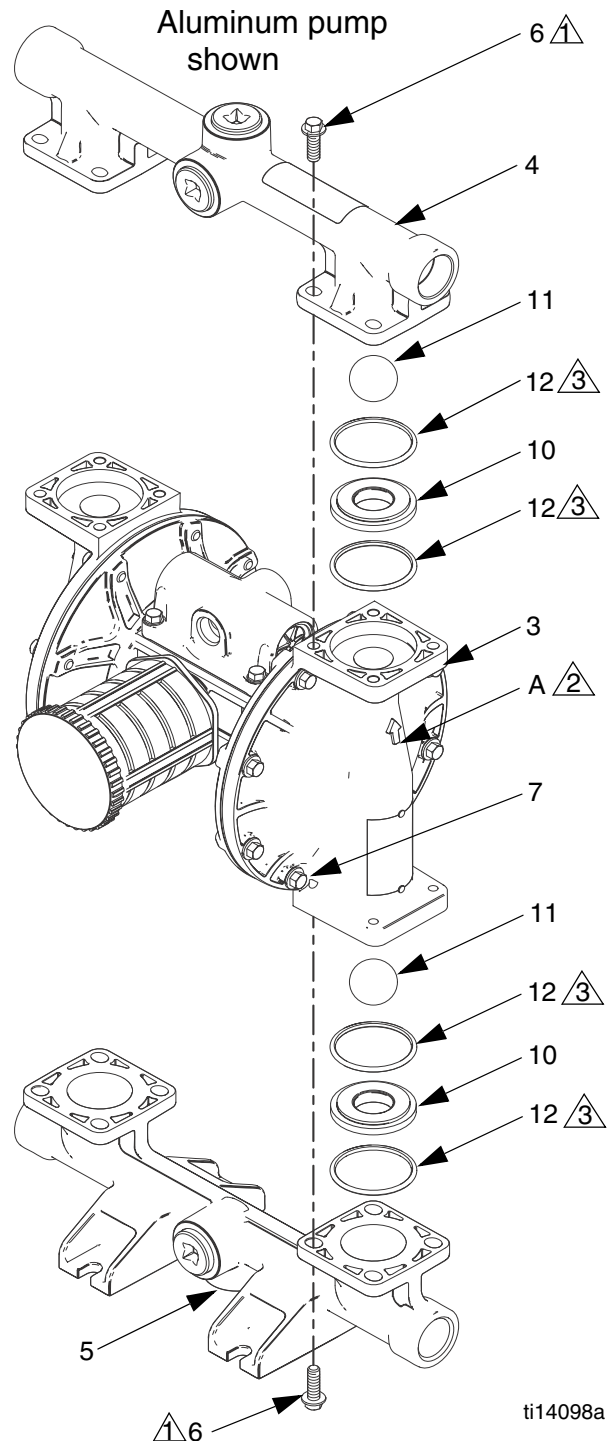
### Reassembly

1. Clean all parts and inspect for wear or damage. Replace parts as needed.
2. Reassemble in the reverse order, following all notes in FIG. 6. Be sure the ball checks (10-12) and manifolds (4, 5) are assembled **exactly** as shown. The arrows (A) on the fluid covers **must** point toward the outlet manifold (4).

⚠ Torque to 100 in-lb (11.3 N•m). See **Torque Instructions**, page 15.

➡ Arrow (A) must point toward outlet manifold.

⊘ Not used on some models.



**FIG. 6. Ball check valve assembly**

## Diaphragms and Center Section



### Disassembly

**NOTE:** Diaphragm kits are available in a range of materials and styles. See page 27 to order the correct diaphragms for your pump. A Center Rebuild Kit also is available. See page 19. Parts included in the Center Rebuild Kit are marked with an \*. For best results, use all kit parts.

1. Follow the **Pressure Relief Procedure** on page 8.
2. Remove the manifolds and disassemble the ball check valves as explained on page 11.
3. **Overmolded Diaphragms**
  - a. Orient the pump so one of the fluid covers faces up. Use a 10 mm socket wrench to remove the fluid cover screws (7), then pull the fluid cover (3) up off the pump.
  - b. The exposed diaphragm (15) will screw off by hand from the diaphragm shaft (104). The diaphragm shaft bolt will remain attached to the diaphragm. Remove the air side diaphragm plate (14).
  - c. Turn the pump over and remove the other fluid cover. Pull the diaphragm and shaft up through the center housing.
  - d. Grasp the diaphragm firmly and use a wrench on the flats of the shaft to remove. Also remove the air side diaphragm plate (14). Continue with Step 5.
4. **All Other Diaphragms**
  - a. Orient the pump so one of the fluid covers faces up. Use a 10 mm socket wrench to remove the fluid cover screws (7), then pull the fluid cover up off the pump. Turn the pump over and remove the other fluid cover.

- b. **Plastic Pumps:** Use a 1-1/4 socket or box end wrench on the hex of a fluid side diaphragm plate to remove. Then remove all parts of the diaphragm assembly. See FIG. 7.

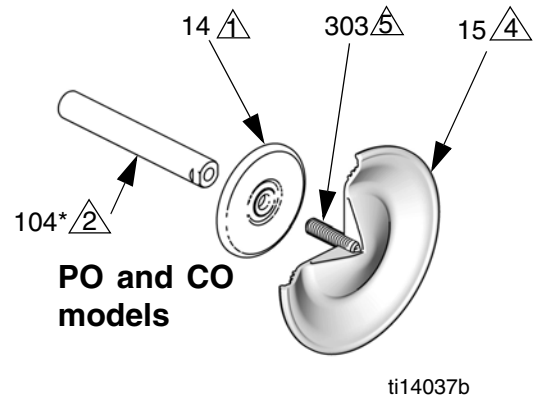
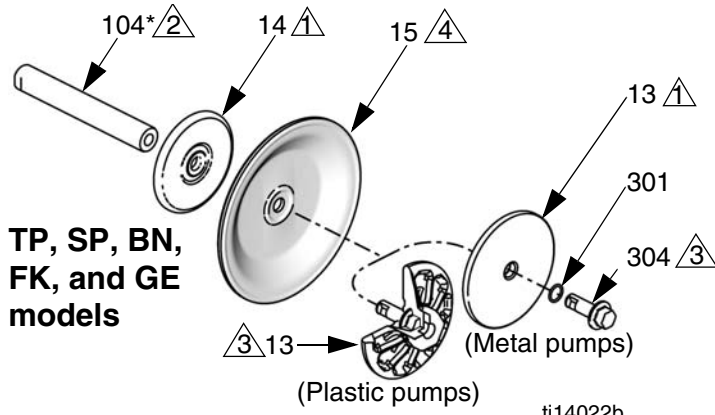
**Metal Pumps:** Remove the bolt (304) from one side of the diaphragm shaft, then remove all parts of that diaphragm assembly. See FIG. 7.

- c. Follow the same procedure to disassemble the other diaphragm assembly.
5. Inspect the diaphragm shaft (104) for wear or scratches. If it is damaged, inspect the bearings (105) in place. If they are damaged, use a bearing puller to remove them.

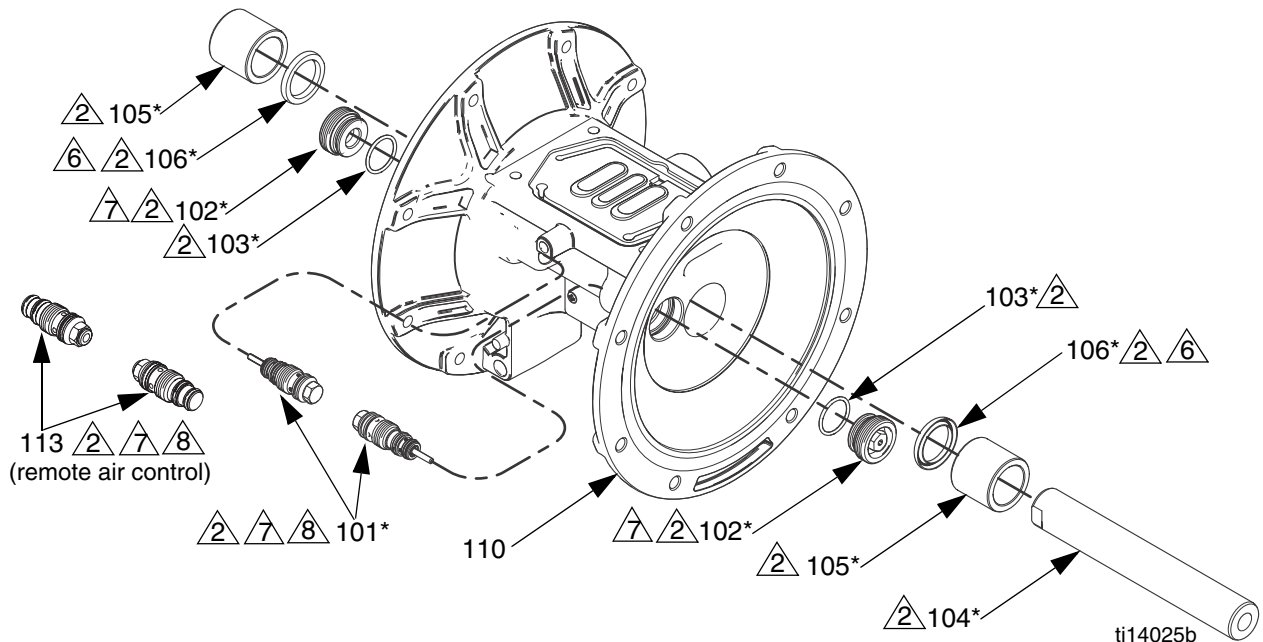
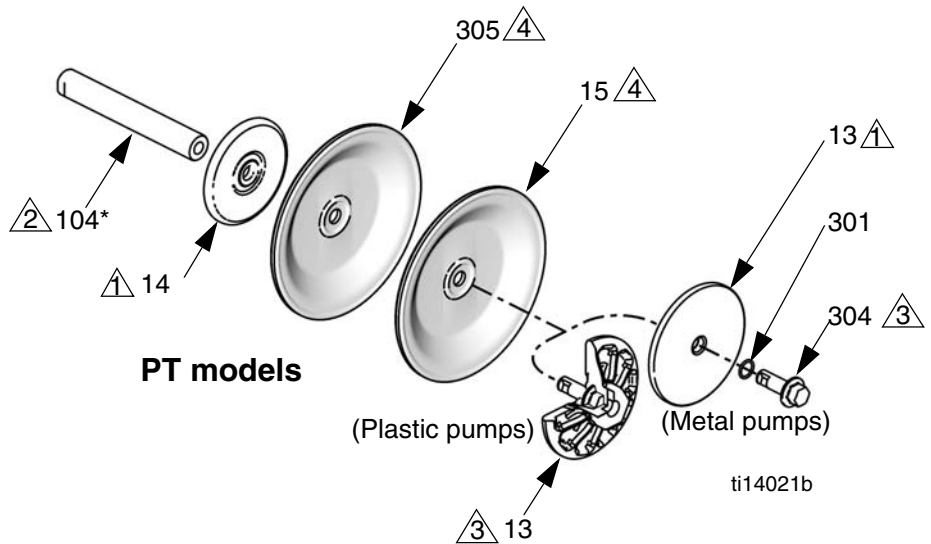
**NOTE: Do not remove undamaged bearings.**

6. Use an o-ring pick to remove the u-cup packings (106) from the center housing. Bearings (105) can remain in place.
7. If necessary, use a socket wrench to remove the pilot valves (101) or pilot inserts (113, remote air control models).
8. Remove the pilot valve cartridges only if necessary due to a known or suspected problem. **After removing pilot valves**, use a hex to remove the cartridges (102), then remove cartridge o-rings (103). If stripped, use two screwdrivers to screw out the cartridge.

**NOTE: Do not remove undamaged pilot valve cartridges.**



- 1 Rounded side faces diaphragm.
- 2 Apply lithium-based grease.
- 3 Torque to 20-25 ft-lb (27-34 N•m) at 100 rpm maximum.
- 4 AIR SIDE markings on diaphragm must face center housing.
- 5 If screw comes loose or is replaced, apply permanent (red) Loctite® or equivalent to diaphragm side threads. Apply primer and medium-strength (blue) Loctite® or equivalent to shaft side threads.
- 6 Lips must face out of housing.
- 7 Cartridges (102) must be installed before pilot valves (101) or inserts (113, for remote air controls).
- 8 Torque to 20-25 in.-lb (2.3-2.8 N•m).



**FIG. 7. Assemble diaphragms and center section**

## Reassembly

Follow all notes in FIG. 7. These notes contain **important** information.

**NOTE:** Apply lithium-based grease whenever instructed to grease.

1. Clean all parts and inspect for wear or damage. Replace parts as needed.
2. If removed, grease and install the new pilot valve cartridges (102) and cartridge o-rings (103). Screw in until seated.

**NOTE:** Cartridges (102) *must* be installed before pilot valves (101).

3. Grease and install the pilot valves (101). Torque to 20-25 in.-lb (2.3-2.8 N•m). Do not over-torque.
4. Grease and install the diaphragm shaft u-cup packings (106) so the lips face **out** of the housing.
5. If removed, insert the new bearings (105) into the center housing. Use a press or a block and rubber mallet to press-fit the bearing so it is flush with the surface of the center housing.
6. **Overmolded Diaphragms:**
  - a. Clamp the shaft flats in a vise.
  - b. If diaphragm setscrew comes loose or is replaced, apply permanent (red) Loctite® or equivalent to diaphragm side threads. Screw into diaphragm until tight.
  - c. Assemble the air side plate (14) onto the diaphragm. The rounded side of the plate must face the diaphragm.
  - d. Apply medium-strength (blue) Loctite or equivalent to the threads of the diaphragm assembly. Screw the assembly into the shaft as tight as possible by hand.
  - e. Grease the shaft u-cups (106) and the length and ends of the diaphragm shaft (104). Slide the shaft into the housing.
  - f. Reattach the first fluid cover (3). See **Torque Instructions**, page 15.
  - g. Repeat Steps b and c for the other diaphragm assembly. Go to Step 7.

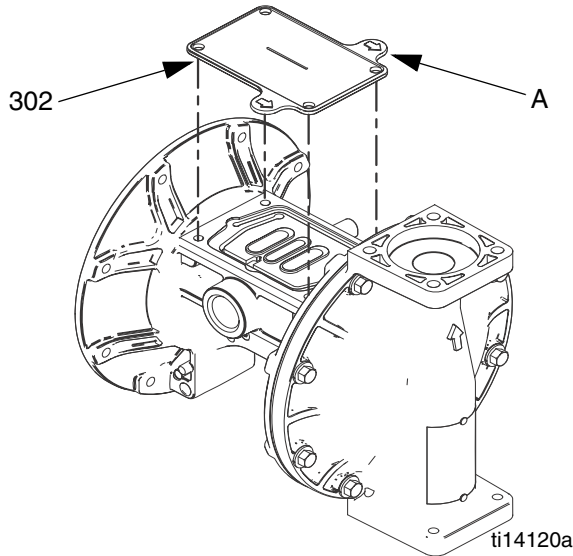
## All Other Diaphragms - Metal Pumps:

- a. Install the o-ring (301) on the shaft bolt (304).
- b. Assemble the fluid side plate (13), the diaphragm (15), the backup diaphragm (305, if present), and the air side diaphragm plate (14) on the bolt exactly as shown in FIG. 7.
- c. Apply medium-strength (blue) Loctite or equivalent to the bolt (304) threads. Screw the bolt into the shaft hand tight.
- d. Grease the shaft u-cups (106) and the length and ends of the diaphragm shaft (104). Slide the shaft into the housing.
- e. Repeat Steps a-c for the other diaphragm assembly.
- f. Hold one shaft bolt with a wrench and torque the other bolt to 20-25 ft-lb (27-34 N•m) at 100 rpm maximum. Do not over-torque.
- g. Reattach the first fluid cover (3). See **Torque Instructions**, page 15. Go to Step 7.

## All Other Diaphragms - Plastic Pumps:

- a. Assemble the diaphragm (15), the backup diaphragm (305, if present), and the air side diaphragm plate (14) on the fluid side plate (13) exactly as shown in FIG. 7.
- b. Apply medium-strength (blue) Loctite or equivalent to the threads of the screw on the fluid side plate. Screw the assembly into the shaft hand-tight.
- c. Grease the shaft u-cups (106) and the length and ends of the diaphragm shaft (104). Slide the shaft into the housing.
- d. Repeat for the other diaphragm assembly
- e. Hold one of the plates with a wrench, and torque the other plate to 20-25 ft-lb (27-34 N•m) at 100 rpm maximum. Do not over-torque.
- f. Reattach the first fluid cover (3). See **Torque Instructions**, page 15.

7. To ensure proper seating and extend diaphragm life, attach the second fluid cover with air pressure on the pump.
  - a. See FIG. 8. Place the supplied tool (302) where the air valve gasket (108) normally goes. Arrows (A) must face toward the fluid cover that is already attached.



**FIG. 8. Fluid cover tool**

- b. Reattach the air valve.
- c. Supply a minimum of 20 psi (0.14 MPa, 1.4 bar) air pressure to the air valve. Shop air may be used. The diaphragm will shift so the second fluid cover will seat properly. Keep air pressure on until the second fluid cover is attached.
- d. Attach the second fluid cover (3). See **Torque Instructions**, page 15.
- e. Remove the air valve and the tool (302), replace the gasket (108), and reattach the air valve. See **Torque Instructions**, page 15.

**NOTE:** If you are replacing the diaphragms but not the air valve, you must remove the air valve and gasket, put the tool in place of the gasket, and put the air valve back on to get the air pressure needed for proper installation of the second fluid cover. Remember to remove the tool and replace the gasket when finished.

8. Reassemble the ball check valves and manifolds as explained on page 11.

## Torque Instructions

**NOTE:** Fluid cover and manifold fasteners have a thread-locking adhesive patch applied to the threads. If this patch is worn, the screws may loosen during operation. Replace screws with new ones, or apply medium-strength (blue) Loctite or equivalent to the threads.

If fluid cover or manifold fasteners have been loosened, it is important to torque them using the following procedure to improve sealing.

**NOTE:** Always completely torque fluid covers before torquing manifolds.

Start all fluid cover screws a few turns. Then turn down each screw just until head contacts cover. Then turn each screw by 1/2 turn or less working in a crisscross pattern to specified torque. Repeat for manifolds.

### Fluid cover and manifold fasteners:

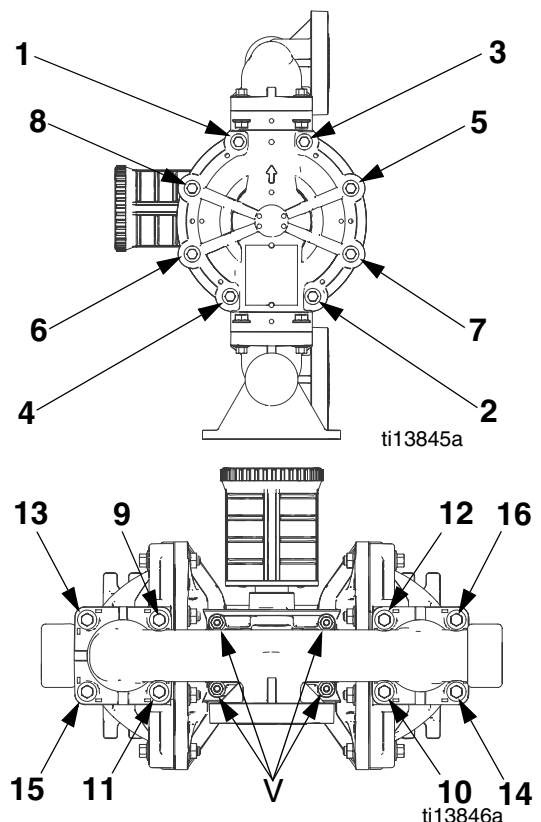
100 in-lb (11.3 N•m)

Retorque the air valve fasteners (V) in a crisscross pattern to specified torque.

### Air valve fasteners:

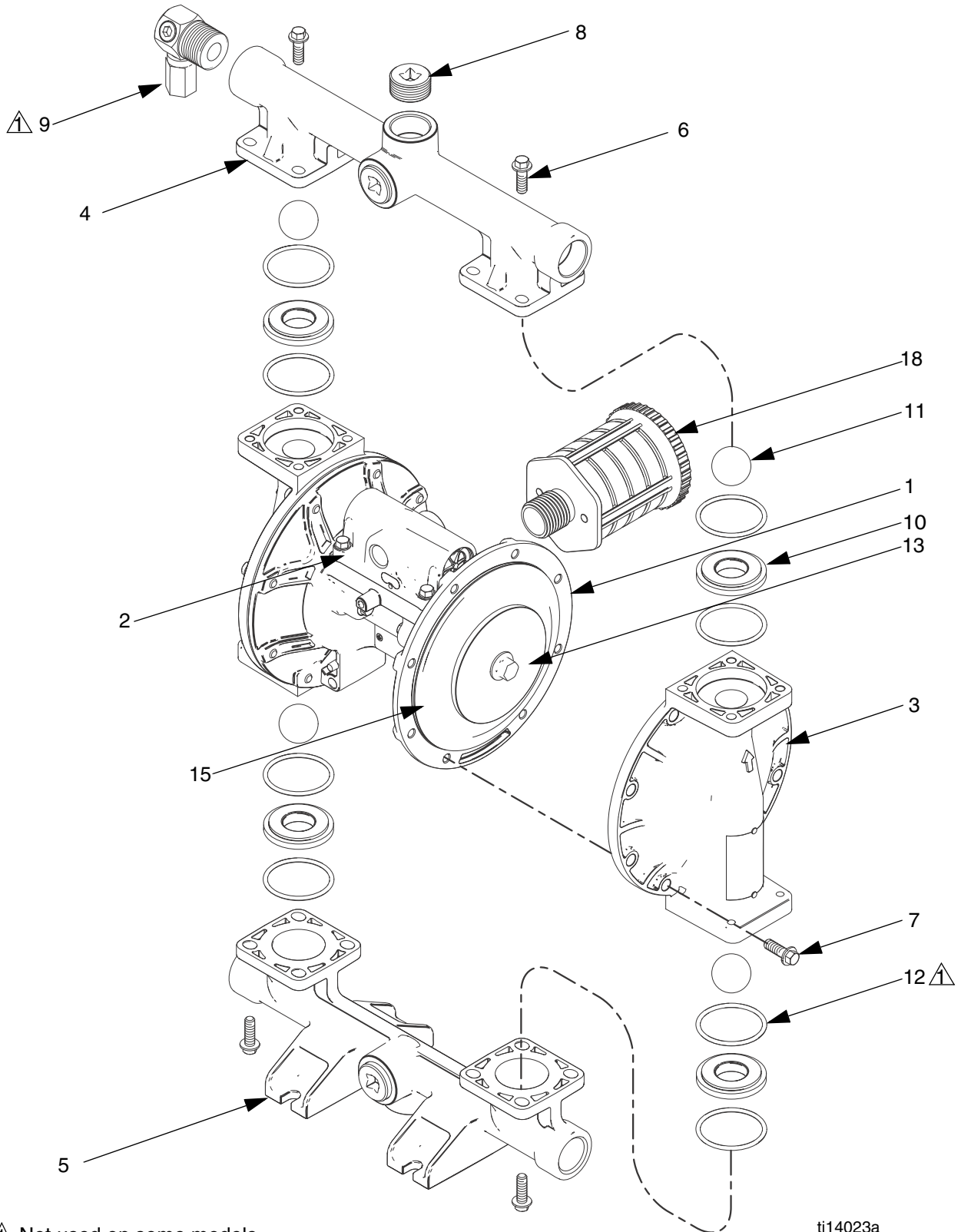
55 in-lb (6.2 N•m) for **plastic center sections**

80 in-lb (9.0 N•m) for **metal center sections**



**FIG. 9. Torque sequence**

# Parts





## Parts/Kits Quick Reference

Use this table as a quick reference for parts/kits. See pages indicated in table for full description of kit contents.

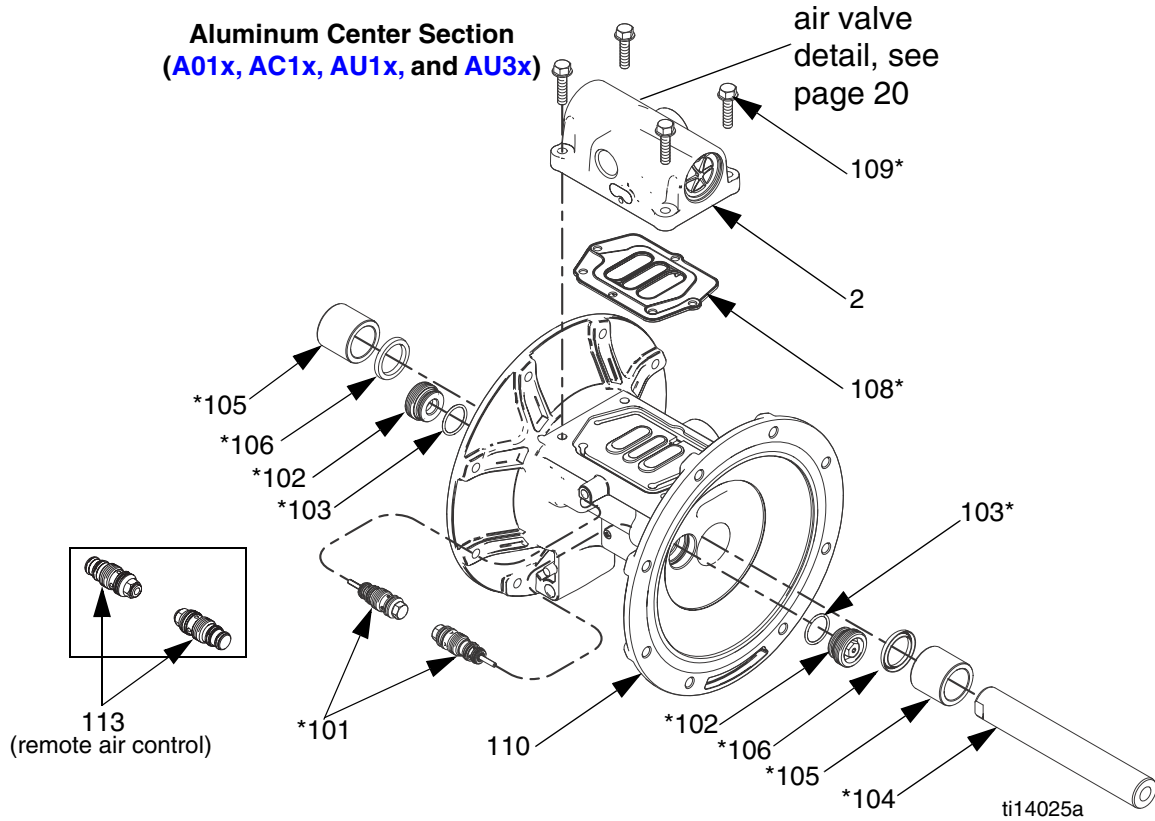
Ref.	Part/Kit	Description	Qty.
1	Varies	Center Section; not sold separately, <i>see page 18</i> Aluminum Conductive Polypropylene Polypropylene	1
2	Varies	Air Valve; <i>see page 20</i>	1
3	24B653 24C051 24D347 24C050 24C052 24C061	Fluid Cover Kits; <i>see page 24</i> Aluminum Conductive Polypropylene Hastelloy Polypropylene PVDF Hastelloy	2
4	24B649 24B650 24C039 24C042 24D343 24D344 24C038 24C041 24C040 24C043 24C057 24C058	Outlet Manifold Kits; <i>see page 24</i> Aluminum, npt Aluminum, bspt Conductive Poly, center flange Conductive Poly, end flange Hastelloy, npt Hastelloy, bspt Polypropylene, center flange Polypropylene, end flange PVDF, center flange PVDF, end flange Stainless Steel, npt Stainless Steel, bspt	1
5	24B651 24B652 24C045 24C048 24D345 24D346 24C044 24C047 24C046 24C049 24C059 24C060	Inlet Manifold Kits; <i>see page 25</i> Aluminum, npt Aluminum, bspt Conductive Poly, center flange Conductive Poly, end flange Hastelloy, npt Hastelloy, bspt Polypropylene, center flange Polypropylene, end flange PVDF, center flange PVDF, end flange Stainless Steel, npt Stainless Steel, bspt	1
6	24B654 24C056 24C064	Manifold Fasteners; 8-pack, <i>see page 24</i> Aluminum Conductive Poly, Poly, and PVDF Stainless Steel and Hastelloy	16
7	24B654 24C055 24C063  24C056	Fluid Cover Fasteners; 8-pack, <i>see page 24</i> Aluminum Conductive Poly, Poly, and PVDF Stainless Steel or Hastelloy, aluminum center Stainless Steel or Hastelloy, plastic center	16
8	24C617	Plug; 6-pack, aluminum pumps only	6
9	24B910	Pressure Relief Valve; fuel dispense model only, <i>see page 24</i>	1

Ref.	Part/Kit	Description	Qty.
10	24B630 24B631 24B632 24B638 24B633 24B635 24B636 24B637 24B634	Seats; 4-pack, includes 8 o-rings where needed, <i>see page 26</i> Acetal Aluminum Buna-N FKM Fluoroelastomer Geolast Polypropylene Santoprene Stainless Steel TPE	4
11	24B639 24B640 24B643 24B644 24B648 24B641 24B645 24B646 24B647 24B642	Check Balls; 4-pack, includes 8 o-rings, <i>see page 26</i> Acetal Buna-N Neoprene Neoprene with SST core FKM Fluoroelastomer Geolast PTFE Santoprene Stainless Steel TPE	4
12	24B655	Manifold O-Ring (not used on some models); ptf, 8-pack, <i>see page 29</i>	8
13	24C035 24C036 24D342 24C036 24C037 24C062	Fluid Side Diaphragm Plate; included in Air and Fluid Plate Kits, <i>see page 28</i> Aluminum Conductive Polypropylene Hastelloy Polypropylene PVDF Stainless Steel	2
14	-----	Air Side Diaphragm Plate (not visible); included in Air and Fluid Plate Kits, <i>see Part 13 or page 28</i>	2
15	24B622 24B629 24B623 24B628 24B624 24B625 24B626 24B627	Diaphragm Kits; <i>see page 27</i> Buna-N Standard FKM Fluoroelastomer Standard Geolast Standard Santoprene Standard TPE Standard Neoprene Overmolded PTFE Overmolded PTFE/EPDM Two-Piece	2
18	112182	Muffler; 3/4 npt, plastic	1
19	116343 116344	Screw, ground, M5 x 0.8; not shown Pumps with aluminum air valve Pumps with conductive poly air valve	1
20▲	188621	Label, warning (not shown)	1

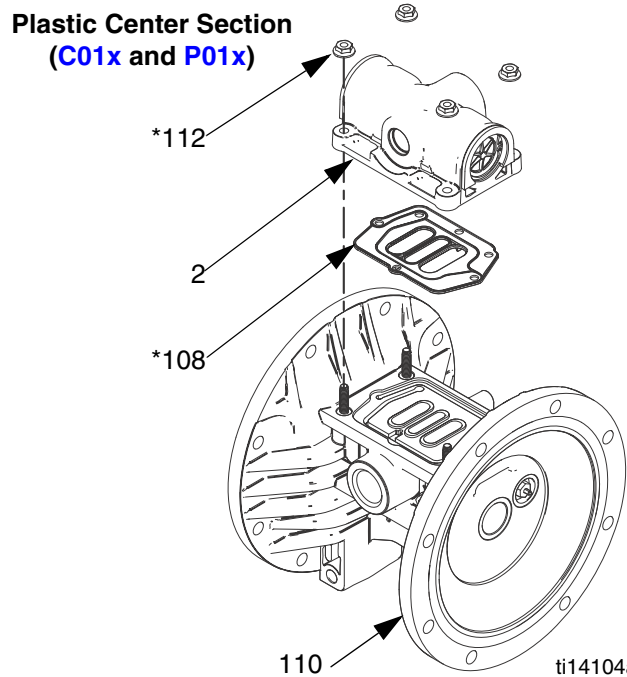
▲ Replacement Warning labels, signs, tags, and cards are available at no cost.

# Center Section

Pump Size and Material		Fluid Covers and Manifolds	Seats	Check Balls	Diaphragm	Manifold O-Rings
1050A	<b>XXXX</b>	A2	AL	BN	TP	PT



Ref.	Description	Qty.
101*	VALVE, pilot	2
102*	CARTRIDGES, pilot valve receiver	2
103*	O-RING, receiver cartridge	2
104*	SHAFT, center	1
105*	BEARING, center shaft	2
106*	U-CUP, center shaft	2
108*	GASKET, air valve	1
109*	SCREW, M6 x 25, stainless steel, (for aluminum center section models, <b>Axxx</b> )	4
110	HOUSING, center, not sold separately	1
112*	NUTS (for plastic center section models, <b>C01x</b> and <b>P01x</b> )	4
113	INSERT, remote pilot (for remote air control models, <b>xxxD</b> )	2



\* Included in Center Section Rebuild Kit 24B621

**Kit 24B621, Center Section Rebuild (\*)**  
**All models**

Kit includes:

- 2 pilot valves (101)
- 2 pilot cartridges (102)
- 2 cartridge o-rings, buna-N (103)
- 1 center shaft (104)
- 2 center shaft bearings (105)
- 2 center shaft u-cups (106)
- 1 air valve gasket (108)
- 4 bolts, M6 x 25, for A01x pumps (109)
- 4 nuts, for P01x and C01x pumps (112)
- 8 o-rings, PTFE (12)

**Kit 24B657, Pilot Valve Assembly**  
**Standard, Pulse Count, and DataTrak with runaway protection models (xxxA, xxxB, and xxxC)**

Kit includes:

- 2 pilot valve assemblies (101)
- 2 pilot valve receiver cartridges (102)
- 2 receiver cartridge o-rings (103)

**Kit 24D043, Remote Pilot Inserts**  
**Remote air control models (xxxD)**

Kit includes:

- 2 remote pilot inserts

**Kit 24B656, Center Shaft Kit**  
**All models**

Kit includes:

- 1 center shaft (104)
- 2 center shaft bearings (105)
- 2 center shaft u-cups (106)

**Kit 24B658, Center Shaft Bearing Kit**  
**All models**

Kit includes:

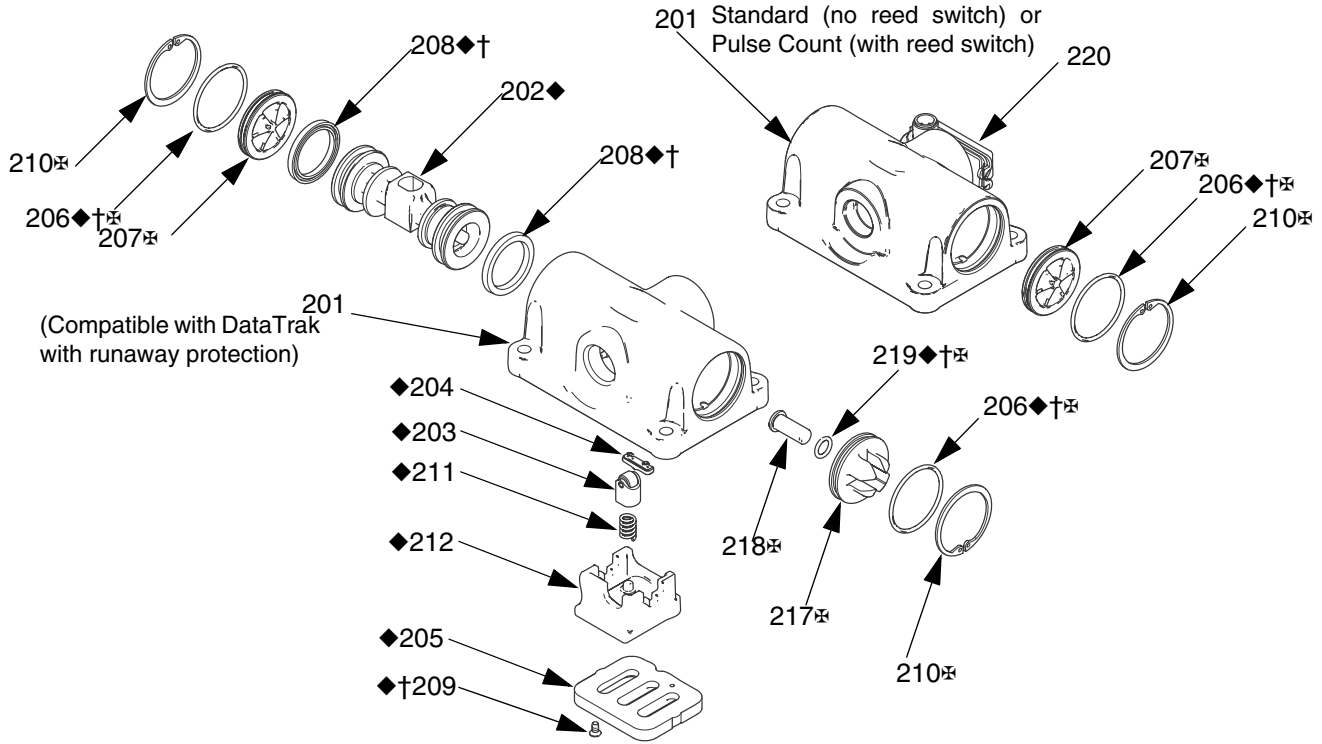
- 2 center shaft bearings (105)
- 2 center shaft u-cups (106)

*The center housing (110) is not sold separately.*

**Ground Screws**

Center Section Material		Ground Screw (19)
A01A-A01D, AU1A, AU3A, and AC1A	Aluminum	116343
C01A-C01D	Conductive Polypropylene	116344
P01A-P01D	Polypropylene	None

# Air Valve and Data Monitoring



ti14027a

Ref.	Description	Qty.
201	HOUSING, not sold separately	1
202◆	PISTON	1
203◆	DETENT PISTON ASSEMBLY	1
204◆	CAM, detent	1
205◆	PLATE, air valve	1
206◆†⊖	O-RING	2
207⊖	CAP, end Standard (xxxA), Pulse Count (xxxB), or Remote (xxxD) DataTrak (xxxC)	2 1
208◆†	U-CUP	2
209◆†	SCREW	2
210◆⊖	RETAINING RING	2
211◆	DETENT SPRING	1
212◆	CUP	1
217⊖	CAP, end (for DataTrak models with runaway protection, xxxC)	1
218⊖	BUTTON, solenoid release (for DataTrak models with runaway protection, xxxC)	1

Ref.	Description	Qty.
219◆†⊖	O-RING (for DataTrak models with runaway protection, xxxC)	1
220	REED SWITCH ASSEMBLY (for Pulse Count models, xxxB, includes fastener)	1

◆Parts included in Air Valve Repair Kit 24B768.

†Parts included in Air Valve Seals Kit 24B769.

⊖Parts included in Air Valve End Cap Kit. See page 21.

## Kit 24B769, Air Valve Seals (†)

### All Models

Kit includes:

- 2 end cap o-rings (206)
- 2 piston u-cups (208)
- 2 screws, M3, shorter (209, for metal pumps)
- 2 screws, #4, longer (209, for plastic pumps)
- 1 solenoid release button o-ring (219)
- 1 air valve gasket (108)

### Air Valve End Cap Kits (⌘)

**Standard or Pulse Count** (no runaway protection solenoid) kits include:

- 2 end caps (207)
- 2 retaining rings (210)
- 2 o-rings (206)

Center Section Material		Monitoring	Air Valve End Cap Kit
AxxA, A01B, or A01D	Aluminum	Standard, Pulse Count, or Remote	24A361
C01A, C01B, or C01D	Conductive Polypropylene	Standard, Pulse Count, or Remote	24C053
P01A, P01B, or P01D	Polypropylene	Standard, Pulse Count, or Remote	24C053

**DataTrak** (runaway protection solenoid) Kits include:

- 1 standard end cap (207)
- 1 end cap with opening (217)
- 2 retaining rings (210)
- 2 o-rings (206)
- solenoid release button (218)
- o-ring for button (219)

Center Section Material		Monitoring	Air Valve End Cap Kit
A01C	Aluminum	DataTrak, with runaway protection	24A363
C01C	Conductive Polypropylene	DataTrak, with runaway protection	24C054
P01C	Polypropylene	DataTrak, with runaway protection	24C054

### Air Valve Repair (◆)

Kits include:

- 1 air valve piston (202)
- 1 detent piston assembly (203)
- 1 detent cam (204)
- 1 air valve plate (205)
- 2 end cap o-rings (206)
- 2 piston u-cups (208)
- 2 screws, M3, shorter (209, for metal pumps)
- 2 screws, #4, longer (209, for plastic pumps)
- 1 detent spring (211)
- 1 air cup (212)
- 1 solenoid release button o-ring (219)
- 1 air valve gasket (108)

Center Section Number	Air Valve Style	Air Valve Repair Kit
A01A-A01C, AU1A, AU3A, AC1A, C01A-C01C, P01A-P01C	Standard, Pulse Count, DataTrak with Runaway Protection	24B768
A01D, C01D, P01D	Remote Air Control	24D044

### Remote Air Control Conversion Kits

Kits include:

- 1 air valve assembly (2) with restrictor
- 1 air valve gasket (108)
- 4 screws (109; models with aluminum centers)  
**OR**
- 4 nuts (112; models with plastic centers)
- 2 remote pilot inserts

Air Valve Material	Conversion Kit
Aluminum	24D037
Conductive Polypropylene	24D039
Polypropylene	24D038

### Pulse Count Kit

Kit includes:

- reed switch module (220)
- mounting screw

Air Valve Material	Pulse Count Kit
Aluminum	24B798
Conductive Polypropylene or Polypropylene	24B796

## Complete Air Valve Replacement Kits

Kits include:

- 1 air valve assembly (2)
- 1 air valve gasket (108)
- 4 screws (109; models with aluminum centers) **OR**
- 4 nuts (112; models with plastic centers)

Center Section Material		Monitoring	Air Valve Replacement Kit
AxxA	Aluminum	Standard (no monitoring)	24B766
A01B		Pulse Count	24B766
A01C		DataTrak, with runaway protection	24B767
A01D		Remote	24D040
C01A	Conductive Polypropylene	Standard (no monitoring)	24B775
C01B		Pulse Count	24B775
C01C		DataTrak, with runaway protection	24B776
C01D		Remote	24D042
P01A	Polypropylene	Standard (no monitoring)	24B773
P01B		Pulse Count	24B773
P01C		DataTrak, with runaway protection	24B774
P01D		Remote	24D041



## Fluid Covers and Manifolds

Pump Size and Material	Air Valve and Center Section		Seats	Check Balls	Diaphragm	Manifold O-Rings
1050A	A01A	<b>XX</b>	AL	BN	TP	PT

### Manifold Fasteners (9)

Fluid Cover and Manifold Material	Kit	Description	Qty.
A1, A2	Aluminum	24B654 BOLT, hex head, steel, M8 x 25	8
C1, C2 P1, P2, F1, F2	Cond. poly Polypropylene PVDF	24C056 BOLT, flange head, M8 x 32, stainless steel, includes nuts	8
S1, S2, H1, H2 with any center (Axxx, Cxxx, or Pxxx)	Stainless steel Hastelloy	24C064 BOLT, hex head, M8 x 20, stainless steel, includes nuts	8

### Fluid Cover Fasteners (7)

Fluid Cover and Manifold Material	Kit	Description	Qty.
A1, A2	Aluminum	24B654 BOLT, hex head, steel, M8 x 25	8
C1, C2 P1, P2, F1, F2	Cond. poly Polypropylene PVDF	24C055 BOLT, flange head, M8 x 45, stainless steel, includes nuts	8
S1, S2, H1, H2 aluminum center (Axxx)	Stainless steel Hastelloy	24C063 BOLT, flange head, M8 x 25, stainless steel	8
S1, S2, H1, H2 plastic center (Cxxx or Pxxx)	Stainless steel Hastelloy	24C056 BOLT, flange head, M8 x 32, stainless steel, includes nuts	8

### Fluid Covers

Kits include:

- 1 fluid cover (3)
- 4 o-rings, ptfe (12)

Fluid Cover and Manifold Material	Fluid Cover Kit	
A1, A2	Aluminum	24B653
C1, C2	Conductive Polypropylene	24C051
H1, H2	Hastelloy	24D347
P1, P2	Polypropylene	24C050
F1, F2	PVDF	24C052
S1, S2	Stainless Steel	24C061

### Kit 24B910, Fluid Pressure Relief Valve Fuel Dispense Model only

Kit includes:

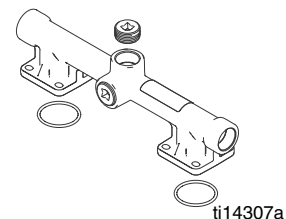
- 1 valve, 3/8 nptf (9)

**NOTE:** See page 29 for manifold o-rings (12).

### Aluminum Outlet Manifold

Kits include:

- 1 outlet manifold (4)
- 3 pipe plugs (8)
- 4 o-rings, ptfe (12)
- 1 warning label (20▲)



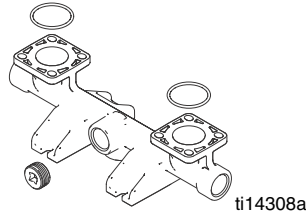
Fluid Cover and Manifold Material	Porting	Outlet Manifold Kit	
A1	Aluminum	npt	24B649
A2	Aluminum	bspt	24B650



### Aluminum Inlet Manifolds

Kits include:

- 1 inlet manifold (5)
- 3 pipe plugs (8)
- 4 o-rings, ptfе (12)

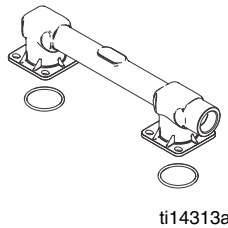


Fluid Cover and Manifold Material		Porting	Inlet Manifold Kit
A1	Aluminum	npt	24B651
A2	Aluminum	bspt	24B652

### Hastelloy and Stainless Steel Outlet Manifolds

Kits include:

- 1 outlet manifold (4)
- 4 o-rings, ptfе (12)
- 1 warning label (20▲)

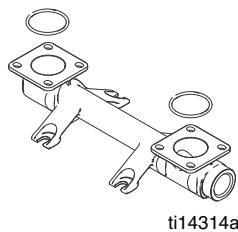


Fluid Cover and Manifold Material		Porting	Outlet Manifold Kit
H1	Hastelloy	npt	24D343
H2	Hastelloy	bspt	24D344
S1	Stainless Steel	npt	24C057
S2	Stainless Steel	bspt	24C058

### Hastelloy and Stainless Steel Inlet Manifolds

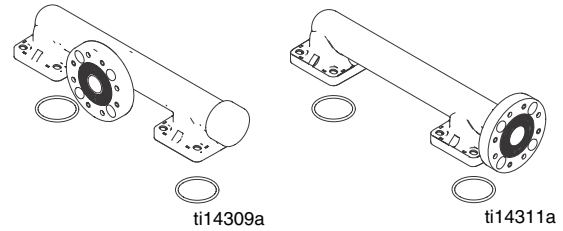
Kits include:

- 1 inlet manifold (5)
- 4 o-rings, ptfе (12)



Fluid Cover and Manifold Material		Porting	Inlet Manifold Kit
H1	Hastelloy	npt	24D345
H2	Hastelloy	bspt	24D346
S1	Stainless Steel	npt	24C059
S2	Stainless Steel	bspt	24C060

### Plastic Outlet Manifolds

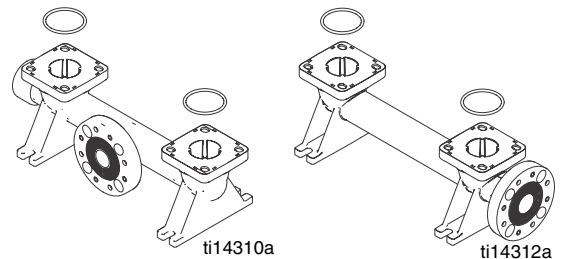


Kits include:

- 1 outlet manifold (4)
- 4 o-rings, ptfе (12)
- 1 warning label (20▲)

Fluid Cover and Manifold Material		Porting	Outlet Manifold Kit
C1	Conductive Poly	Center flange	24C039
C2	Cond. Poly	End flange	24C042
P1	Polypropylene	Center flange	24C038
P2	Polypropylene	End flange	24C041
F1	PVDF	Center flange	24C040
F2	PVDF	End flange	24C043

### Plastic Inlet Manifolds



Kits include:

- 1 inlet manifold (5)
- 4 o-rings, ptfе (12)

Fluid Cover and Manifold Material		Porting	Inlet Manifold Kit
C1	Conductive Poly	Center flange	24C045
C2	Conductive Poly	End flange	24C048
P1	Polypropylene	Center flange	24C044
P2	Polypropylene	End flange	24C047
F1	PVDF	Center flange	24C046
F2	PVDF	End flange	24C049

▲ Replacement Danger and Warning tags, labels, and cards are available at no cost.

Pump Size and Material	Air Valve and Center Section	Fluid Covers and Manifolds			Diaphragm	Manifold O-Rings
1050A	A01A	A2	XX	XX	TP	PT

## Seats

**NOTE:** Some kits may not be available for your model. See the selector tool at [www.graco.com](http://www.graco.com) or speak with your distributor.

Kits include:

- 4 seats, material indicated in table (10)
- 8 o-rings, PTFE, included unless table says “not used” (12)

Seat Material	Kit
AC Acetal	24B630
AL Aluminum	24B631
BN Buna-N (o-rings not used)	24B632
FK FKM Fluoroelastomer (o-rings not used)	24B638
GE Geolast	24B633
PP Polypropylene	24B635
PV PVDF	24C721
SP Santoprene	24B636
SS Stainless steel	24B637
TP TPE (o-rings not used)	24B634

## Check Balls

**NOTE:** Some kits may not be available for your model. See the selector tool at [www.graco.com](http://www.graco.com) or speak with your distributor.

Kits Include:

- 4 balls, material indicated in table (11)
- 8 o-rings, PTFE (12)

Check Ball Material	Kit
AC Acetal	24B639
BN Buna-N	24B640
CR Neoprene®	24B643
CW Neoprene® with stainless steel core	24B644
FK FKM Fluoroelastomer	24B648
GE Geolast®	24B641
PT PTFE	24B645
SP Santoprene®	24B646
SS Stainless Steel	24B647
TP TPE	24B642

# Diaphragms

Pump Size and Material	Air Valve and Center Section	Fluid Covers and Manifolds	Seats	Check Balls		Manifold O-Rings
1050A	A01A	A2	AL	BN	<b>XX</b>	PT

**NOTE:** Some kits may not be available for your model. See the selector tool at [www.graco.com](http://www.graco.com) or speak with your distributor.

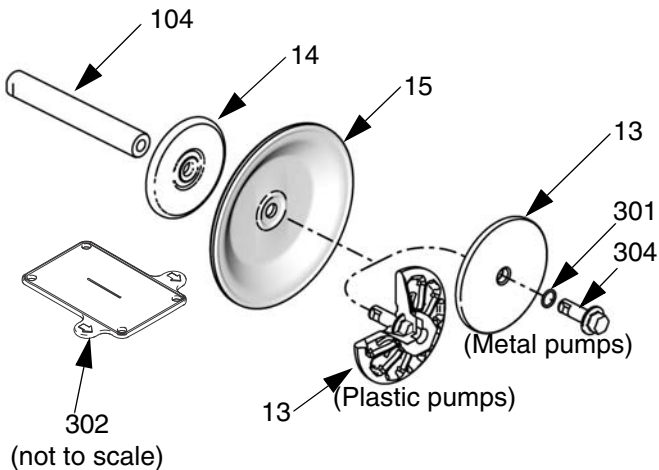
## Standard Diaphragms

Kits include:

- 8 o-rings, ptf (12)
- 2 diaphragms (15, material indicated in table)
- 2 o-rings for the bolt (301, used only on metal pumps)
- 1 diaphragm install tool (302)

**NOTE:** See page 28 to order a diaphragm shaft bolt (304) if needed.

Diaphragm Material	Kit
<b>BN</b> Buna-N	24B622
<b>FK</b> FKM Fluoroelastomer	24B629
<b>GE</b> Geolast	24B623
<b>SP</b> Santoprene	24B628
<b>TP</b> TPE	24B624



ti14022a

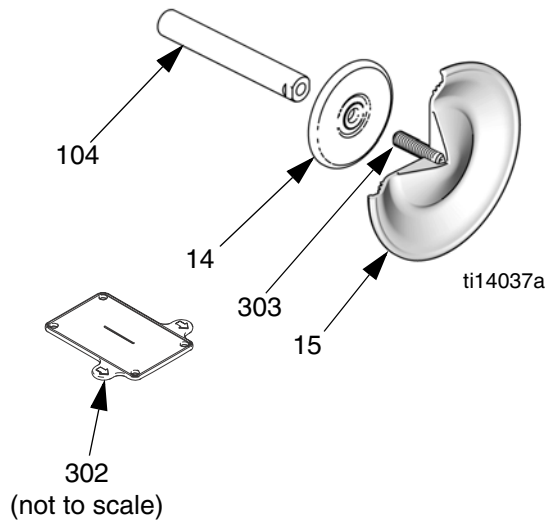
## Overmolded Diaphragms

Kits include:

- 8 o-rings, ptf (12)
- 2 overmolded diaphragms (15, material indicated in table)
- 2 diaphragm set screws, stainless steel (303)
- 1 diaphragm install tool (302)

**NOTE:** See page 28 to order a diaphragm shaft bolt (304) if needed.

Diaphragm Material	Kit
<b>CO</b> Neoprene	24B625
<b>PO</b> PTFE	24B626



ti14037a

## Diaphragms (continued)

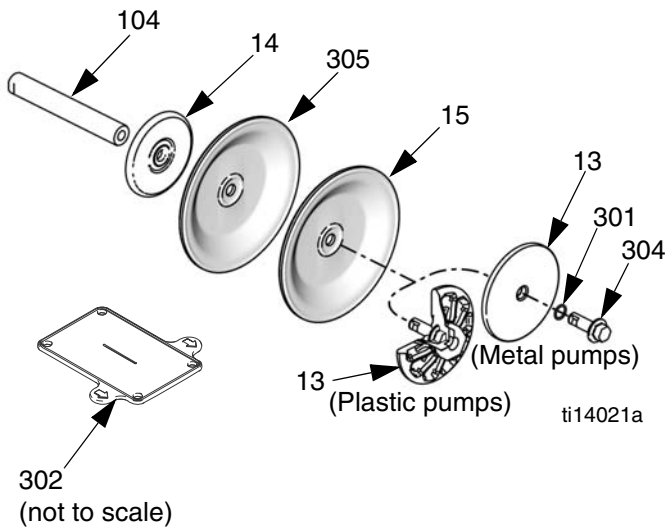
Pump Size and Material	Air Valve and Center Section	Fluid Covers and Manifolds	Seats	Check Balls		Manifold O-Rings
1050A	A01A	A2	AL	BN	XX	PT

### Two-Piece Diaphragms

Kits include:

- 8 o-rings, PTFE (12)
- 2 diaphragms, PTFE (15)
- 2 backup diaphragms, EPDM (305)
- 2 o-rings for the bolt (301, used only on metal pumps)
- 1 diaphragm install tool (302)

Diaphragm Material	Kit
PT	PTFE and EPDM
	24B627



### Air and Fluid Plates

Kits for **aluminum, hastelloy, and stainless steel** pumps include:

- air side diaphragm plate (14)
- fluid side diaphragm plate (13)
- o-ring (301)
- bolt (304)

Kits for **polypropylene, conductive polypropylene, and PVDF** pumps include:

- air side diaphragm plate (14)
- fluid side diaphragm plate (13, includes bolt)

Pump Material	Air and Fluid Plate Kit
Aluminum	24C035
Conductive Polypropylene	24C036
Hastelloy	24D342
Polypropylene	24C036
PVDF	24C037
Stainless Steel	24C062

### Diaphragm Shaft Bolt (Metal Pumps)

Kit 24C099 includes:

- 8 bolts, stainless steel, M12 x 35 (304)
- 8 o-rings (301)

## Manifold O-Rings

Pump Size and Material	Air Valve and Center Section	Fluid Covers and Manifolds	Seats	Check Balls	Diaphragm	
1050A	A01A	A2	AL	BN	TP	XX

Kit Includes:

- 8 o-rings, PTFE (12)

O-Ring	Kit	Qty.
PT	24B655	8
--	Model includes no o-rings	0

## DataTrak

**NOTE:** See DataTrak manual, 313840, for all DataTrak related part numbers and kit information, including the reed switch and solenoid.

## Accessories

### Fluid Pressure Relief Kit 238428

(for aluminum pumps)

Includes pipe bushings, hose adapter, relief valve, and tubing.

### Fluid Pressure Relief Kit 112119

(for plastic pumps)

Includes fluid pressure relief valve.

### Wall Mount Kit 24C637

Includes bracket, 4 dampeners, 8 washers, and 8 lock nuts.

### Wall Bracket Dampener Kit 24E769

Includes 4 dampeners.

### Rubber Foot Mounting Kit 236452

Includes washers, nuts, and rubber feet.

### Grounding Wire Assembly Kit 238909

Includes ground wire and clamp.

### Air Controls Kit 246946

Includes 1/4 npt air filter/regulator with 40 micron element and air pressure gauge.

### Air Controls Kit 246947

Includes 1/2 npt air filter/regulator with 40 micron element and air pressure gauge.

### Standard Pipe Flange Kits

239005 - Polypropylene

239008 - Stainless steel

239009 - PVDF

Each kit includes the pipe flange, a PTFE gasket, bolts, spring lock washers, flat washers and nuts.

### Low-Ice Muffler

Part No. 102656, 3/4 npt, aluminum.

# Technical Data

Maximum fluid working pressure . . . . .	125 psi (0.86 MPa, 8.6 bar)
Air pressure operating range . . . . .	20-125 psi (0.14-0.86 MPa, 1.4-8.6 bar)
Fluid displacement per cycle . . . . .	0.17 gal. (0.64 liters)
Air consumption at 70 psi (0.48 MPa, 4.8 bar), 20 gpm (76 lpm) . . . . .	25 scfm
Maximum values with water as media under submerged inlet conditions at ambient temperature:	
Maximum air consumption . . . . .	67 scfm
Maximum free-flow delivery . . . . .	50 gpm (189 lpm)
Maximum pump speed. . . . .	280 cpm
Maximum suction lift . . . . .	16 ft (4.9 m) dry, 29 ft (8.8 m) wet
Maximum size pumpable solids . . . . .	1/8 in. (3.2 mm)
Sound Power*	
at 70 psi (0.48 MPa, 4.8 bar) and 50 cpm . . . . .	78 dBA
at 100 psi (0.7 MPa, 7.0 bar) and full flow . . . . .	90 dBA
Sound Pressure**	
at 70 psi (0.48 MPa, 4.8 bar) and 50 cpm . . . . .	84 dBA
at 100 psi (0.7 MPa, 7.0 bar) and full flow . . . . .	96 dBA
Fluid temperature range. . . . .	see page 31
Air inlet size . . . . .	1/2 npt(f)
Fluid inlet size	
Aluminum (1050A), Hastelloy (1050H) or Stainless Steel (1050S) . . . . .	1 in. npt(f) or 1 in. bspt
Conductive Poly (1050C), Polypropylene (1050P), or PVDF (1050F) . . . . .	1 in. raised face ANSI/DIN flange
Fluid outlet size	
Aluminum (1050A), Hastelloy (1050H) or Stainless Steel (1050S) . . . . .	1 in. npt(f) or 1 in. bspt
Conductive Poly (1050C), Polypropylene (1050P), or PVDF (1050F) . . . . .	1 in. raised face ANSI/DIN flange
Weight	
Aluminum (1050A) . . . . .	23 lb. (10.5 kg)
Conductive Polypropylene (1050C) and Polypropylene (1050P) . . . . .	18 lb. (8.2 kg)
Hastelloy . . . . .	41 lb. (18.6 kg)
PVDF (1050F) . . . . .	26 lb (11.8 kg)
Stainless Steel (1050S)	
with conductive polypropylene center . . . . .	36.3 lb. (16.5 kg)
with polypropylene center . . . . .	37.3 lb. (16.9 kg)
with aluminum center. . . . .	41.4 lb. (18.8 kg)
Wetted parts include material(s) chosen for seat, ball, and diaphragm options, <b>plus</b> the pump's material of construction	
1050A . . . . .	Aluminum
1050H . . . . .	Hastelloy
1050C and 1050P . . . . .	Polypropylene
1050F . . . . .	PVDF
1050S . . . . .	Stainless Steel

Non-wetted external parts

Aluminum (1050A) . . . . .	aluminum, coated carbon steel
Hastelloy (1050H). . . . .	hastelloy, stainless steel, polypropylene or aluminum (if used in center section)
Plastic (1050P, 1050C, and 1050F) . . . . .	stainless steel, polypropylene
Stainless Steel (1050S) . . . . .	stainless steel, polypropylene or aluminum (if used in center section)

\* Sound power measured per ISO-9614-2.

\*\* Sound pressure was tested 3.28 ft (1 m) from equipment.

All trademarks mentioned in this manual are the property of their respective owners.

### Fluid Temperature Range

**NOTICE**

Temperature limits are based on mechanical stress only. Certain chemicals will further limit the fluid operating temperature range. Stay within the temperature range of the most-restricted wetted component. Operating at a fluid temperature that is too high or too low for the components of your pump may cause equipment damage.

Diaphragm/Ball/Seat Material	Fluid Temperature Range					
	Aluminum, Hastelloy, or Stainless Steel Pumps		Polypropylene or Conductive Polypropylene Pumps		PVDF Pumps	
	Fahrenheit	Celsius	Fahrenheit	Celsius	Fahrenheit	Celsius
Acetal (AC)	10° to 180°F	-12° to 82°C	32° to 150°F	0° to 66°C	10° to 180°F	-12° to 82°C
Buna-N (BN)	10° to 180°F	-12° to 82°C	32° to 150°F	0° to 66°C	10° to 180°F	-12° to 82°C
FKM Fluoroelastomer (FK)*	-40° to 275°F	-40° to 135°C	32° to 150°F	0° to 66°C	10° to 225°F	-12° to 107°C
Geolast® (GE)	-40° to 150°F	-40° to 66°C	32° to 150°F	0° to 66°C	10° to 150°F	-12° to 66°C
Neoprene overmolded diaphragm (CO) or Neoprene check balls (CR or CW)	0° to 180°F	-18° to 82°C	32° to 150°F	0° to 66°C	10° to 180°F	-12° to 82°C
Polypropylene (PP)	32° to 150°F	0° to 66°C	32° to 150°F	0° to 66°C	32° to 150°F	0° to 66°C
PTFE overmolded diaphragm (PO)	40° to 180°F	4.0° to 82°C	40° to 150°F	4° to 66°C	40° to 180°F	4.0° to 82°C
PTFE check balls or two-piece PTFE/EPDM diaphragm (PT)	40° to 220°F	4° to 104°C	40° to 150°F	4° to 66°C	40° to 220°F	4° to 104°C
PVDF (PV)	10° to 225°F	-12° to 107°C	32° to 150°F	0° to 66°C	10° to 225°F	-12° to 107°C
Santoprene® (SP)	-40° to 180°F	-40° to 82°C	32° to 150°F	0° to 66°C	10° to 180°F	-12° to 82°C
TPE (TP)	-20° to 150°F	-29° to 66°C	32° to 150°F	0° to 66°C	10° to 150°F	-12° to 66°C

\* The maximum temperature listed is based on the ATEX standard for T4 temperature classification. If you are operating in a non-explosive environment, FKM fluoroelastomer's maximum fluid temperature in aluminum or stainless steel pumps is 320°F (160°C).

# Graco Standard Husky Pump Warranty

Graco warrants all equipment referenced in this document which is manufactured by Graco and bearing its name to be free from defects in material and workmanship on the date of sale to the original purchaser for use. With the exception of any special, extended, or limited warranty published by Graco, Graco will, for a period of five years from the date of sale, repair or replace any part of the equipment determined by Graco to be defective. This warranty applies only when the equipment is installed, operated and maintained in accordance with Graco's written recommendations.

This warranty does not cover, and Graco shall not be liable for general wear and tear, or any malfunction, damage or wear caused by faulty installation, misapplication, abrasion, corrosion, inadequate or improper maintenance, negligence, accident, tampering, or substitution of non-Graco component parts. Nor shall Graco be liable for malfunction, damage or wear caused by the incompatibility of Graco equipment with structures, accessories, equipment or materials not supplied by Graco, or the improper design, manufacture, installation, operation or maintenance of structures, accessories, equipment or materials not supplied by Graco.

This warranty is conditioned upon the prepaid return of the equipment claimed to be defective to an authorized Graco distributor for verification of the claimed defect. If the claimed defect is verified, Graco will repair or replace free of charge any defective parts. The equipment will be returned to the original purchaser transportation prepaid. If inspection of the equipment does not disclose any defect in material or workmanship, repairs will be made at a reasonable charge, which charges may include the costs of parts, labor, and transportation.

**THIS WARRANTY IS EXCLUSIVE, AND IS IN LIEU OF ANY OTHER WARRANTIES, EXPRESS OR IMPLIED, INCLUDING BUT NOT LIMITED TO WARRANTY OF MERCHANTABILITY OR WARRANTY OF FITNESS FOR A PARTICULAR PURPOSE.**

Graco's sole obligation and buyer's sole remedy for any breach of warranty shall be as set forth above. The buyer agrees that no other remedy (including, but not limited to, incidental or consequential damages for lost profits, lost sales, injury to person or property, or any other incidental or consequential loss) shall be available. Any action for breach of warranty must be brought within six (6) years of the date of sale.

**GRACO MAKES NO WARRANTY, AND DISCLAIMS ALL IMPLIED WARRANTIES OF MERCHANTABILITY AND FITNESS FOR A PARTICULAR PURPOSE, IN CONNECTION WITH ACCESSORIES, EQUIPMENT, MATERIALS OR COMPONENTS SOLD BUT NOT MANUFACTURED BY GRACO.** These items sold, but not manufactured by Graco (such as electric motors, switches, hose, etc.), are subject to the warranty, if any, of their manufacturer. Graco will provide purchaser with reasonable assistance in making any claim for breach of these warranties.

In no event will Graco be liable for indirect, incidental, special or consequential damages resulting from Graco supplying equipment hereunder, or the furnishing, performance, or use of any products or other goods sold hereto, whether due to a breach of contract, breach of warranty, the negligence of Graco, or otherwise.

## **FOR GRACO CANADA CUSTOMERS**

The Parties acknowledge that they have required that the present document, as well as all documents, notices and legal proceedings entered into, given or instituted pursuant hereto or relating directly or indirectly hereto, be drawn up in English. Les parties reconnaissent avoir convenu que la rédaction du présente document sera en Anglais, ainsi que tous documents, avis et procédures judiciaires exécutés, donnés ou intentés, à la suite de ou en rapport, directement ou indirectement, avec les procédures concernées.

## Graco Information

For the latest information about Graco products, visit [www.graco.com](http://www.graco.com).

**TO PLACE AN ORDER**, contact your Graco distributor or call to identify the nearest distributor.

**Phone:** 612-623-6921 **or Toll Free:** 1-800-328-0211 **Fax:** 612-378-3505

*All written and visual data contained in this document reflects the latest product information available at the time of publication.  
Graco reserves the right to make changes at any time without notice.*

*Original instructions. This manual contains English. MM 313435*

**Graco Headquarters:** Minneapolis

**International Offices:** Belgium, China, Japan, Korea

**GRACO INC. P.O. BOX 1441 MINNEAPOLIS, MN 55440-1441**

Copyright 2009, Graco Inc. is registered to ISO 9001

[www.graco.com](http://www.graco.com)

Revised 03/2010