

RANGER

VORTEX submersible pumps

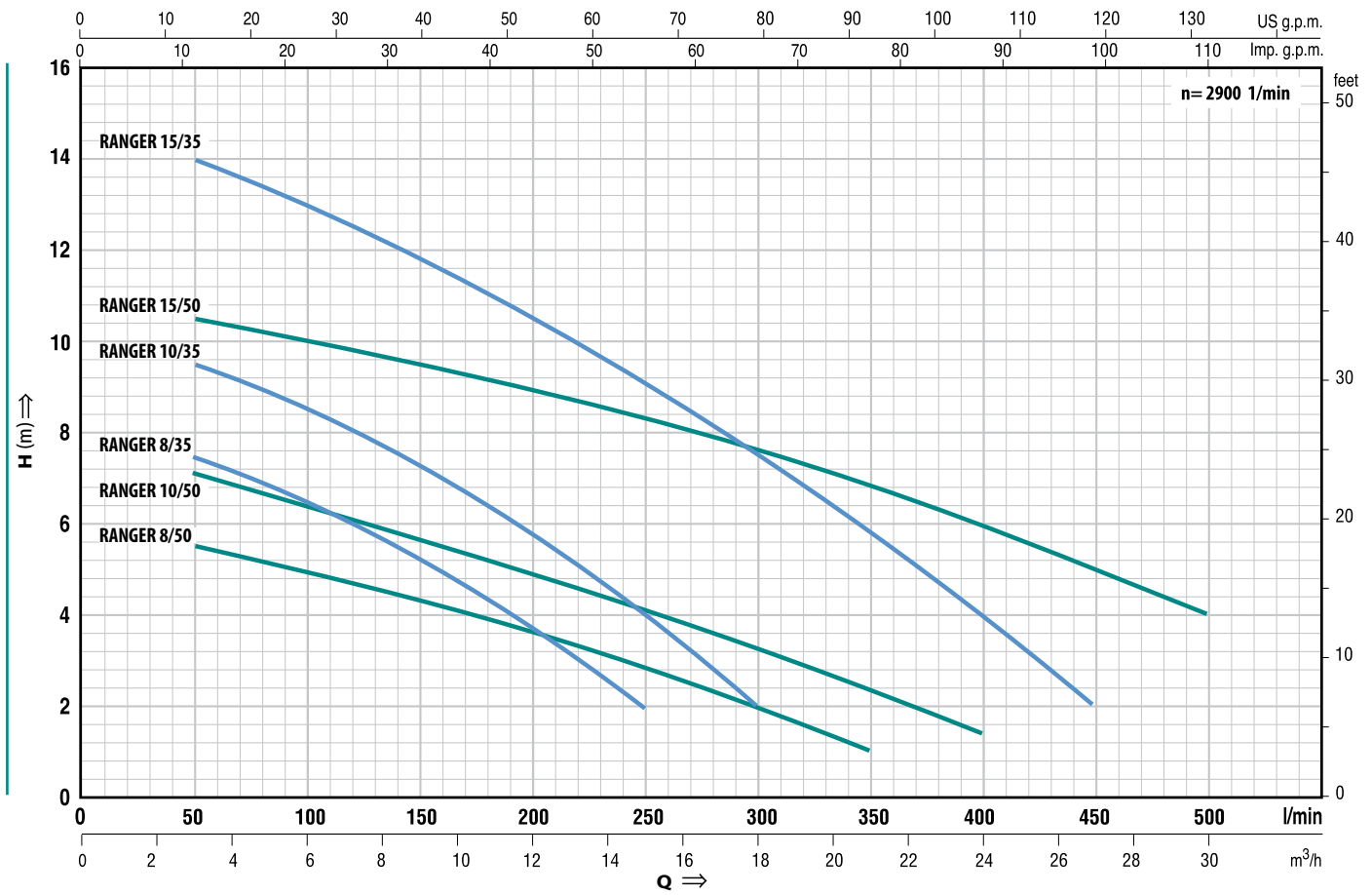

Q = Flow rate H = Total manometric head

Tolerance of the performance curves according to EN ISO 9906 App. A.

TYPE		POWER		m ³ /h l/min	0	3	6	9	12	15	18	21	24	27	30	
Single-phase	Three-phase	kW	HP		0	50	100	150	200	250	300	350	400	450	500	
RANGER 8/35M	---	0.60	0.85	H metres	8.4	7.5	6.5	5.2	3.7	2						
RANGER 10/35M	RANGER 10/35	0.75	1		10	9.5	8.5	7.2	5.8	4	2					
RANGER 15/35M	RANGER 15/35	1.1	1.5		15	14	13	11.8	10.5	9	7.5	6	4	2		
RANGER 8/50M	---	0.60	0.85		6	5.5	5	4.4	3.6	2.8	2	1				
RANGER 10/50M	RANGER 10/50	0.75	1		7.5	7	6.5	5.8	5	4	3.2	2.4	1.5			
RANGER 15/50M	RANGER 15/50	1.1	1.5		11	10.5	10	9.5	9	8.3	7.5	6.8	6	5	4	

DIMENSIONS AND WEIGHTS

TYPE		PORT DN	passage of solid bodies	DIMENSIONS mm									kg	
Single-phase	Three-phase			a	b	c	h	h1	d	e	p	∅	1~	3~
RANGER 8/35M	---	1 1/2"	∅ 35 mm	105	87	137	380	123	40	adjustable	500	500	12.4	-
RANGER 10/35M	RANGER 10/35				92	143	400	133					13.5	12.1
RANGER 15/35M	RANGER 15/35			110	90	150	410	153	55				15.7	14.6
RANGER 8/50M	---	2"	∅ 50 mm	110	90	150	410	153	65				13.4	-
RANGER 10/50M	RANGER 10/50				120	97	163	430					158	13.9
RANGER 15/50M	RANGER 15/50			120	97	163	430	158	65				16.1	15.0



RANGE OF PERFORMANCE

Flow rate up to 500 l/min (30 m³/h)

Head up to 15 m

LIMITS OF USE

Depth up to 5 m

Liquid temperature up to + 40°C

Passage of suspended solid bodies up to
Ø 50 mm

For continuous duty: minimum immer-
sion 290 mm from pump base

INSTALLATION AND USE

THEY ARE RECOMMENDED FOR DOMESTIC, CIVIL AND INDUSTRIAL USE, IN APPLICATIONS WHERE THE WATER CONTAINS SUSPENDED SOLIDS WITH DIMENSIONS UP TO Ø 50 mm. THEIR USE IS RECOMMENDED FOR DRYING FLOODED AREAS SUCH AS CELLARS, UNDERGROUND CAR PARKS, CAR WASHING AREAS, OR DOMESTIC DRAINS AND FOR EMPTYING CESSPITS OR SEWAGE DISPOSAL. THESE PUMPS ARE OUTSTANDING IN THEIR RELIABILITY IN FIXED INSTALLATIONS WITH AUTOMATIC OPERATION.

GUARANTEE 2 YEARS: subject to our general terms of sale.

CONSTRUCTION CHARACTERISTICS

- **DELIVERY BODY:** cast iron, with threaded port ISO 228/1.
 - **MOTOR CASING:** stainless steel AISI 304.
 - **BASE:** stainless steel AISI 304.
 - **IMPELLER:** stainless steel AISI 304.
 - **MOTOR SHAFT:** stainless steel EN 10088-3 - 1.4104.
 - **DOUBLE SEAL:** mechanical seal silicon carbide-ceramic-NBR, with oil barrier chamber and inner lip seal to protect the seal in the event of dry running.
 - **MOTOR:** submersible asynchronous for continuous duty.
- RANGER M:** single-phase 220÷240 V - 50 Hz with capacitor and thermal overload protector.
RANGER: three-phase 380÷415 V - 50 Hz.
- **INSULATION:** class F.
 - **PROTECTION:** IP 68.

STANDARD FEATURES:

RANGER M (single-phase)

- Float switch.
- Neoprene power cable "H07 RN-F" length 5 metres with Schuko plug.

RANGER (three-phase)

- Neoprene power cable "H07 RN-F" length 5 metres.

OPTIONS ON REQUEST

⇒ 10 metres power cable. N.B. required for outdoor use to comply to standard EN 60335-2-41



- ⇒ control panel for three-phase pumps 1.1 kW
- ⇒ single-phase pumps without float switch
- ⇒ other voltages or frequency 60 Hz

CONSTRUCTION AND SAFETY STANDARDS

EN 60 335-1

EN 60034-1

IEC 335-1

IEC 34-1

CEI 61-150

CEI 2-3



DIMENSIONS

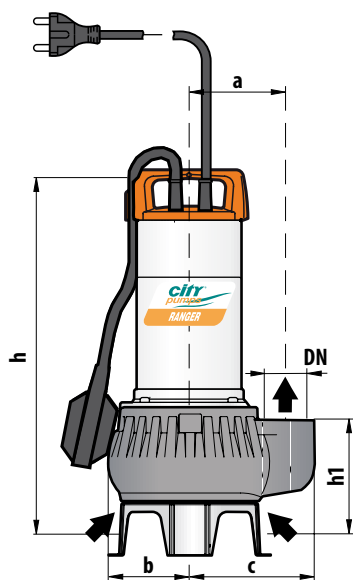

Typical single-phase installation

