

# Husky 716 Metal Pumps

## Air-Operated Double-Diaphragm

---

### Features

- 3/4 in (19.05 mm) center- and end-porting
- No seals to leak or fail
- Quiet running — less than 85 dBa with easy-to-use remote muffler capability for even lower noise levels
- High flow rates in a small, portable package
- External controller for optional remote operation

### Typical Applications

- Machine lubrication servicing
- Cleaning fluids and detergents
- Plating and dip tanks
- Water treatment

### Typical Fluids Handled

- Oil
- Water
- Most solvents



*Husky 716 Aluminum  
D53XXX or D43XXX*



*Husky 716 Stainless Steel  
D54XXX or D44XXX*

# Husky 716

## Metal Pumps

### Technical Specifications

Maximum fluid working pressure	100 psi (7 bar, 0.7 MPa)
Maximum free flow delivery*	16 gpm (61 lpm)
Maximum pump speed	400 cpm
Displacement per cycle**	0.04 gallon (0.15 liter)
Maximum suction lift (D53331)	11 ft (3.4 m) dry
Maximum size pumpable solids	0.09 in (2.5 mm)
Maximum operating temperature***	
PTFE	220°F (104.4°C)
Santoprene	180°F (82.2°C)
Buna-N	180°F (82.2°C)
TPE	150°F (65.5°C)
Fluoroelastomer	250°F (121.1°C)
Typical sound level at 70 psi air (4.9 bar, 0.49 MPa) air @ 200 cpm	74 dBa
Maximum air consumption	28 scfm (0.672 m3/min)
Air pressure operating range	25 to 100 psi (1.8 to 7 bar, 0.18 to 0.7 MPa)
Air inlet size	1/4 npt(f)
Air exhaust port size	3/8 npt(f)
Fluid inlet & outlet size	3/4 npt(f) or bspt(f)
Weight	
Aluminum	8.5 lb (3.9 kg)
Stainless Steel	18 lb (8.2 kg)
Wetted parts (in addition to ball, seat and diaphragm materials—which may vary by pump)	
Aluminum pump	Aluminum, Stainless Steel, PTFE, Zinc-Plated Steel
Stainless Steel pump	Polypropylene, Stainless Steel, Polyester, Nickel-Plated Brass, Epoxy-Coated Steel
Instruction manual	308981

\* Flow rates are with muffler and do not vary based on diaphragm material

\*\* Displacement per cycle may vary based on suction condition, discharge head, air pressure and fluid type

\*\*\* Actual pump performance may be affected by prolonged usage at temperature

### System Drawings

Husky 716 Wall-Mount with Drum Feed

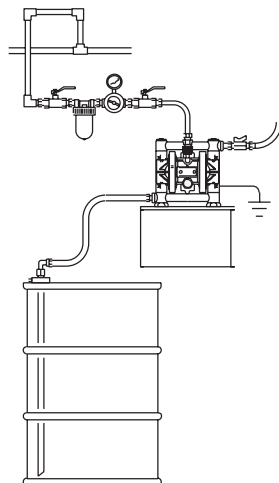

Husky 716 Drum-Mount with Siphon Feed

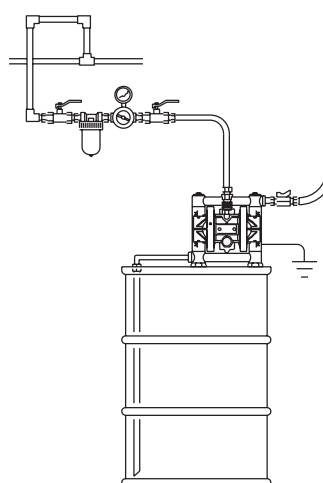

# Husky 716

## Metal Pumps

### Ordering Information

The highlighted areas indicate possible configurations for the Husky 716 metal pumps.

PUMP SIZE (AIR MOTOR TYPE AND MATERIAL)	WETTED PARTS	SEATS	BALLS	DIAPHRAGM
1 = 1/4" (6.35 mm) Standard: polypropylene center section	1 = Acetal (npt)	0 = Seat with ball	1 = PTFE	1 = PTFE
2 = 1/4" (6.35 mm) Remote: polypropylene center section	2 = Poly (npt)	2 = Acetal	2 = Acetal	5 = TPE
3 = 3/8" (9.52 mm) Standard: aluminum center section	3 = Aluminum (npt)	3 = Stainless Steel	3 = Stainless Steel	6 = Santoprene
5 = 1/2" (12.7 mm) Standard: polypropylene center section	4 = Stainless Steel (npt)	4 = Hardened SST	4 = Hardened SST	7 = Buna N
4 = 1/2" (12.7 mm) Remote: polypropylene center section	5 = PVDF (npt)	5 = TPE	5 = TPE	8 = Fluoroelastomer
5 = 3/4" (19.05 mm) Standard: polypropylene center section	6 = Ductile Iron (npt)	6 = Santoprene	6 = Santoprene	G = Geolast
4 = 3/4" (19.05 mm) Remote: polypropylene center section		7 = Buna N	7 = Buna N	
7 = 1" (25.4 mm) Standard: aluminum center section	A = Acetal ** (bsp)	8 = Fluoroelastomer	8 = Fluoroelastomer	
8 = 1" (25.4 mm) Remote: aluminum center section	B = Poly ** (bsp)	9 = Polypropylene	9 = Polypropylene	
R = 1" (25.4 mm) Standard: stainless steel center section	C = Aluminum (bsp)	A = PVDF	A = PVDF	
S = 1" (25.4 mm) Remote: stainless steel center section	D = Stainless Steel (bsp)	G = Geolast	G = Geolast	
B = 1-1/2" (38.1 mm) Standard: aluminum center section	E = PVDF (bsp)			
C = 1-1/2" (38.1 mm) Remote: aluminum center section	F = Ductile Iron (bsp)	B = SST with viton seal		
T = 1-1/2" (38.1 mm) Standard: stainless steel center section		C = Santoprene with viton seal		
U = 1-1/2" (38.1 mm) Remote: stainless steel center section	H = 2 npt Alum Extended			
F = 2" (50.8 mm) Standard: aluminum center section	G = 2 bsp Alum Extended			
G = 2" (50.8 mm) Remote: aluminum center section		D = Urethane Duckbill		
V = 2" (50.8 mm) Standard: stainless steel center section				
W = 2" (50.8 mm) Remote: stainless steel center section				
K = 3" (76.2 mm) Standard: aluminum center section				

\*\* = BSP plastic in 1/2" (12.7mm) pumps  
 1" > Plastic pumps flange connections  
 3" Aluminum pumps flange connections

### Dimensions

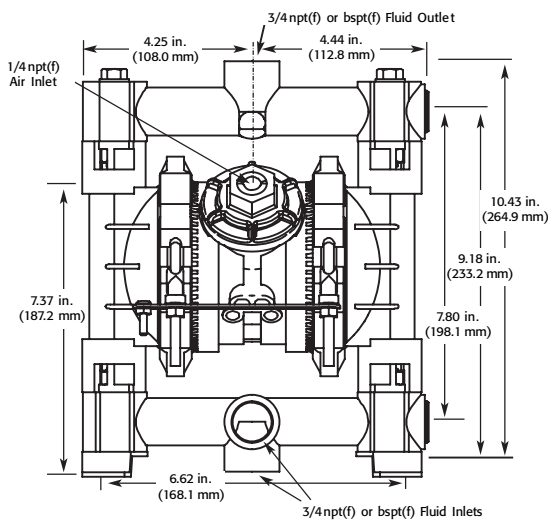

# Husky 716

## Metal Pumps

### Popular Models

Material	Part Number (NPT Ported)		Part Number (BSP Ported)		Materials for Seats	Materials for Balls	Materials for Diaphragms	Fluid Kit	Air Kit	Air Control*
	Standard Air Valve	Remote Air Valve	Standard Air Valve	Remote Air Valve						
Aluminum	D53211	D43211	D5C211	D4C211	Acetal	PTFE	PTFE	D05211	241657	246946
	D53255	D43255	D5C255	D4C255	Acetal	TPE	TPE	D05255	241657	246946
	D53277	D43277	D5C277	D4C277	Acetal	Buna	Buna	D05277	241657	246946
	D53288	D43288	D5C288	D4C288	Acetal	Fluoroelastomer	Fluoroelastomer	D05288	241657	246946
	D53311	D43311	D5C311	D4C311	Stainless Steel	PTFE	PTFE	D05311	241657	246946
	D53331	D43331	D5C331	D4C331	Stainless Steel	Stainless Steel	PTFE	D05331	241657	246946
	D53355	D43355	D5C355	D4C355	Stainless Steel	TPE	TPE	D05355	241657	246946
	D53366	D43366	D5C366	D4C366	Stainless Steel	Santoprene	Santoprene	D05366	241657	246946
	D53377	D43377	D5C377	D4C377	Stainless Steel	Buna	Buna	D05377	241657	246946
	D53388	D43388	D5C388	D4C388	Stainless Steel	Fluoroelastomer	Fluoroelastomer	D05388	241657	246946
	D53911	D43911	D5C911	D4C911	Polypropylene	Polypropylene	Polypropylene	D05911	241657	246946
	D53955	D43955	D5C955	D4C955	Polypropylene	TPE	TPE	D05955	241657	246946
	D53966	D43966	D5C966	D4C966	Polypropylene	Santoprene	Santoprene	D05966	241657	246946
	D53977	D43977	D5C977	D4C977	Polypropylene	Buna	Buna	D05977	241657	246946
	D53D05	D43D05	D5CD05	D4CD05		Duckbill	TPE	D05D05	241657	246946
	D53D06	D43D06	D5CD06	D4CD06		Duckbill	Santoprene	D05D06	241657	246946
	D53D07	D43D07	D5CD07	D4CD07		Duckbill	Buna	D05D07	241657	246946
Stainless Steel	D54211	D44211	D5D211	D4D211	Acetal	PTFE	PTFE	D05211	241657	246946
	D54311	D44311	D5D311	D4D311	Stainless Steel	PTFE	PTFE	D05311	241657	246946
	D54331	D44331	D5D331	D4D331	Stainless Steel	Stainless Steel	PTFE	D05331	241657	246946
	D54335	D44335	D5D335	D4D335	Stainless Steel	Stainless Steel	TPE	D05335	241657	246946
	D54336	D44336	D5D336	D4D336	Stainless Steel	Stainless Steel	Santoprene	D05336	241657	246946
	D54355	D44355	D5D355	D4D355	Stainless Steel	TPE	TPE	D05355	241657	246946
	D54366	D44366	D5D366	D4D366	Stainless Steel	Santoprene	Santoprene	D05366	241657	246946
	D54377	D44377	D5D377	D4D377	Stainless Steel	Buna	Buna	D05377	241657	246946
	D54388	D44388	D5D388	D4D388	Stainless Steel	Fluoroelastomer	Fluoroelastomer	D05388	241657	246946
	D54911	D44911	D5D911	D4D911	Polypropylene	PTFE	PTFE	D05911	241657	246946
	D54966	D44966	D5D966	D4D966	Polypropylene	Santoprene	Santoprene	D05966	241657	246946

\* Air control includes air regulator and filter with gauge

### Performance Charts

See [www.graco.com/process](http://www.graco.com/process) for performance charts.

### Accessories

See page 75 for additional accessories.