

LIQUID SAMPLER 780

General

Automatic sampling from rivers and waste water systems requires high quality, reliable equipment and with 780 Liquid Sampler, MJK has again set new standards for design and function.

Throughout the design process careful consideration has been given to the selection of the best materials for this arduous task, thus the enclosure is stainless steel and all parts that are in contact with the liquid are either glass, stainless steel or plastic. Great care has been taken to ensure reliability. The unit is waterproof to IP55 and all the electronics, valves etc. are contained within the body of the sampler with all the controls being operated from a „soft-touch“ keypad, while any parts which need to be cleaned are mounted externally.

Features

- * Waterproof stainless steel construction.
- * Compact size 165mm x 235mm x 410mm.
- * Wall mounting with 3 screws.
- * Internal (manual) and external (flow and time proportional).
- * Dual supply (12V DC or 110 - 240V AC).
- * Built-in alarm system and self-redress in case of obstruction.

Applications

The 780 Liquid Sampler is designed to take samples from lakes, rivers, sewage systems, pumping stations, etc. The sampler 780 can be connected directly to MJK Flow Converter 713, for flow proportional sampling.

Operation

The 780 Liquid Sampler uses the pressure and vacuum sampling method. When the sampler receives the start signal from either the control panel or an external controller, the sample tube is pressurised to clear it of any residue from the previous sample. The vacuum is then turned on until the sample glass is full. Then the glass is again pressurised to clear the sur-plus liquid from it leaving the required sample (20 to 500ml) in the glass. When the required level is reached the outlet valve opens and the sample runs into the collecting vessel. If the sample does not fill within a set time, it's because the sample tube is blocked, the vacuum is switched off and the sampler repressurises the sample tube to clear the obstruction and starts again. If the sampler fails again the alarm signal is sent and the error display on the control panel is illuminated. As most of the samples should be volume proportional, the sampler 780 is of a robust design and is unaffected by electrical noise, and it can be connected directly to a flow meter.



However, if it is wished to vary the cycle all the functions can be controlled externally via a terminal block, so the control of all the internal functions and the monitoring can be made from a PLC or directly from the process computer of the sewage plant.

Specifications

Mechanical data

Cabinet:	Stainless steel welded construction
Enclosure:	IP55
Weight:	5 kg
Dimensions:	165mm x 235mm x 410mm

Sample data

Cycle Time:	Approx. 2 minutes (adjustable 1-10 mins.)
Sample Size:	20-500 ml
Vacuum:	max. 7,5m
Pressure:	max. 1 bar (pressurise the sample tube)
Inlet Tube:	9 mm i.d. PVC tube
Outlet Tube:	9,5 mm i.d. Silicone tube

Electrical data

Voltage:	12V DC and 220-240/110-120V AC
Consumption:	2W stand-by 30W in operation

7.1

Dimension

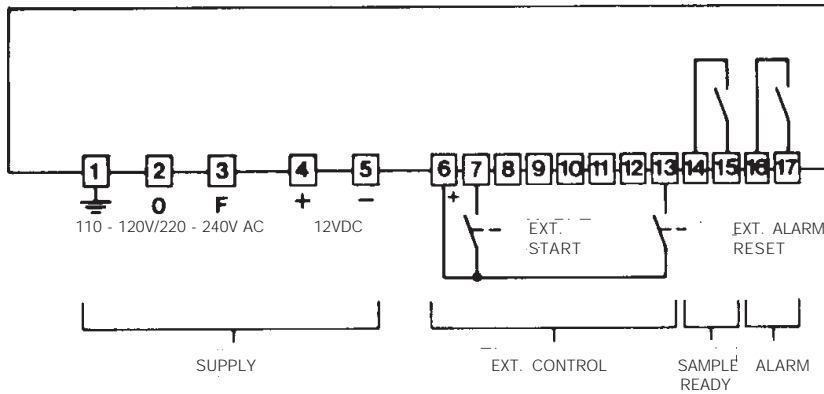

Connection

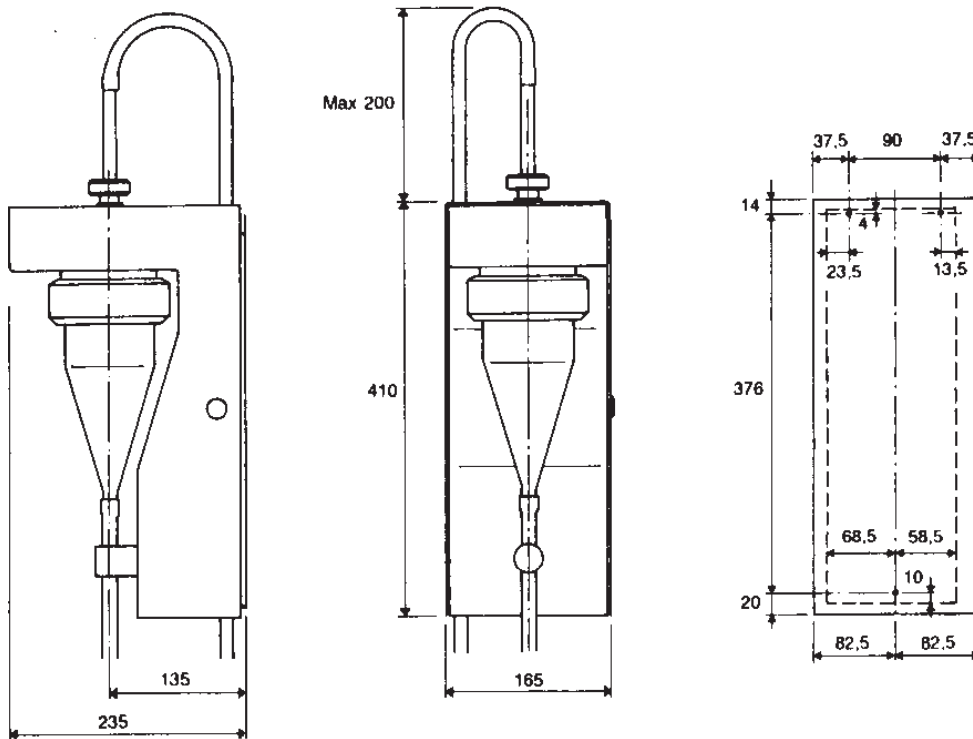

Order nos

Part.no: Specification:
 203520 780-1100 Liquid sampler with 110V/220V AC and 12V DC supply voltage

- Accessories:
- 203550 783-1310 Integrator 0-20mA
 - 203551 783-1320 Integrator 4-20mA
 - 595110 Sample glass
 - 595120 Inlet tube, PVC
 - 595121 Outlet tube, silicone