

*The most durable  
gas chlorinator  
on the market...*



**SERIES 500**

# GAS CHLORINATORS

*For...*

- Potable Water Systems • Industrial Process Water
- Sanitary Sewage • Industrial Waste Water
- Community Water Systems • Power Plants • Swimming Pools & Fountains

**EASY INSTALLATION:**

Advanced product design eliminates the probability of troublesome installations.

**FEWER PARTS:**

Proven product engineering results in fewer parts for exceptional operating reliability, lower cost, and longer life.

**TOTAL RELIABILITY:**

Every part is optimally designed and manufactured using materials proven to be chemically resistant to chlorine gas. Therefore, Hydro Instruments' Series 500 components can be used to handle chlorine gas with safety and complete control at capacities from 4 to 100 lbs/day (75 to 2000 grams/hour).



**INSTRUMENTS**





# GAS CHLORINATORS

*Hydro Series 500 gas chlorinators are designed for manual or semi-automatic operation to meet the highest standards of reliability. They incorporate advanced design features gained through years of research and in-the-field experience. Simplified design and fewer parts mean less maintenance, less cost with better performance, reliability and long life.*

## Principle of Operation

For a particular ejector back pressure, a minimum water supply is required at the ejector inlet to create vacuum at a level strong enough to operate the chlorinator. This vacuum originates in the throat of the ejector's Venturi nozzle and after opening the ejector check valve, extends into the body of the chlorinator. There it causes the regulating diaphragm to open the inlet safety valve, allowing gas under pressure to enter the chlorinator. As it flows across the inlet safety valve assembly, it is filtered and reduced to a vacuum.

The gas then enters a chamber where the vacuum level is maintained by a spring-opposed, sealed regulating diaphragm. It is then drawn through the chlorine flow meter, across the rate control valve and on to the ejector where it dissolves in water. The resultant, highly concentrated solution exits at the ejector outlet and flows to the desired point of application.

## Accuracy

Flow meter accuracy is within 4% of the meter's maximum capacity.

## Capacities Available

100, 50, 25, 10, 4 pounds per day (2000, 1000, 500, 200, 75 grams per hour). Minimum feed rate is 5% of maximum.

## Installation of Hydro Gas Chlorinators

Units of the **Hydro Gas Chlorinator System** can be used for practically any requirement. The schematics show various types of installations using single or multiple cylinders as well as application of chlorine to pool, basin or pipeline...direct or remote. Basic **HYDRO** gas chlorinator units are simply combined to cover all applications. Series 500 chlorinators can be supplied for cylinder, manifold, and ton container mounting. (Manifold mounting requires additional equipment.) When ordering, prefix number with "T" for ton container mounting.

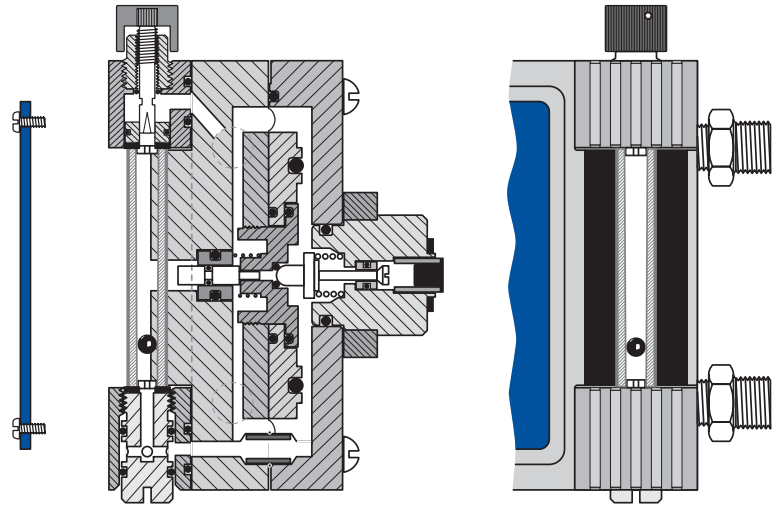

## HYDRO Series 500 Chlorinator

A heavy steel yoke is used to mount the **Hydro chlorinator** directly to the cylinder. **This eliminates all pressure lines.** Chlorine gas is taken under vacuum to the point of injection. **This eliminates pressurized solution lines.**

### Operator Indicator

During operation the indicator window remains gray; red indicates depletion of the chlorine source.

### Inlet Safety Valve

Spring opposed safety valve seals off chlorine in cylinder upon loss of vacuum. Safety valve is encapsulated to permit quick disassembly and cleaning without special tools.

### Inlet Sealing Valve

A sealing valve at the chlorinator inlet closes if chlorine supply is interrupted or depleted, sealing the entire vacuum system. Dirt or moisture cannot enter the system when cylinders are changed.

### Regulating Diaphragm

Constant vacuum level is maintained inside the chlorinator by the diaphragm which is O-ring sealed along its entire inner and outer surface to prevent leakage or warping of parts from excessive tightening of the body bolts.

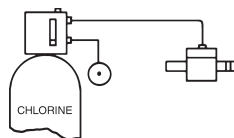

**Hydro Model 500**  
Single-Point Application

**Hydro** chlorinator mounted on a single cylinder with direct ejector to pipeline or basin. Chlorine capacity to 100 PPD (2000 grams/hr).

○ Vent to outside

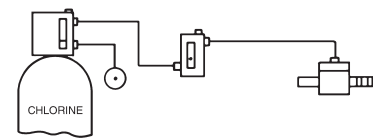

**Hydro Model 501**  
Remote Meter for Single Point of Application

**Hydro** chlorinator mounted on a single cylinder feeding a remote wall mounted meter with rate valve supplying a single ejector. Chlorine capacity to 100 PPD (2000 grams/hr).

# A complete system for totally reliable control.

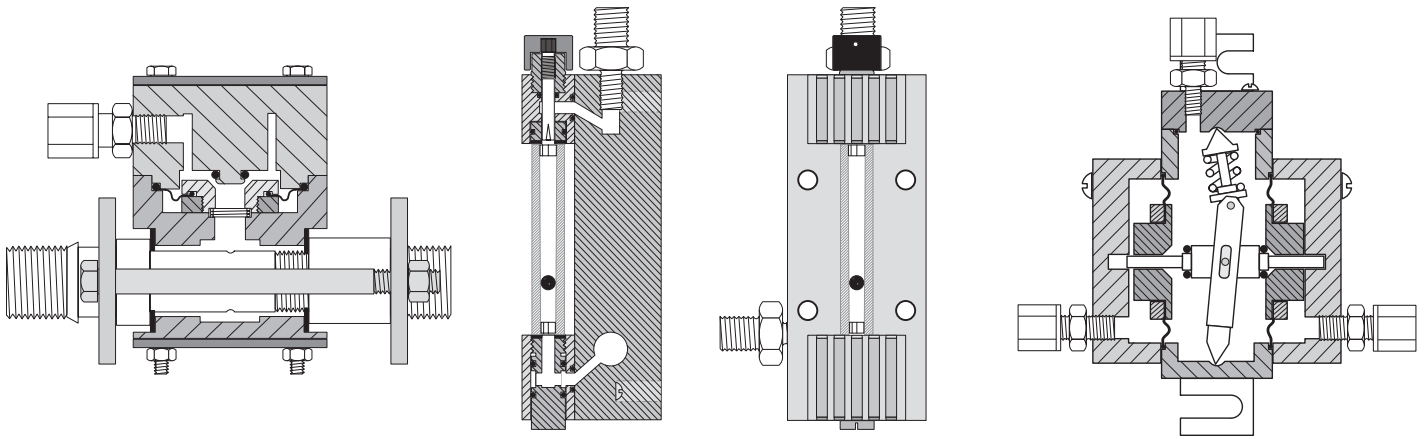

## HYDRO EJ-1000 Ejector

The **Hydro** ejector utilizes a specially designed O-ring seal check valve which prevents the backflow of water into the chlorinator. The ejector operates on a venturi created by water passing through the ejector nozzle causing the spring opposed diaphragm check valve to open and mix the chlorine gas with the water. The ejector should be supplied with reasonable clean water at temperatures below 80°F (27°C). The **Hydro** ejector is made of durable materials that are resistant to wet and dry chlorine gas use.

## HYDRO RM-401 Remote Meter

Any number of **Hydro** Remote Meters may be used in an installation if required. Only the vacuum line is required to the individual ejector which it supplies. Chlorine gas can then be precisely metered at each remote location. If more (or less) is required at one location the meter is simply set at the desired level for that location. By this control of metering at remote locations a perfectly balanced system can be maintained. **Hydro** Remote Meters are practically maintenance free.

## HYDRO SP-100 Automatic Switchover

Multiple chlorine cylinders, which prolong the time span before depletion, are easily installed and automatically switch over from a depleted cylinder to the unused cylinder. A **Hydro** Chlorinator is installed on each cylinder and only one Automatic Switchover is required to handle the two cylinders. The **Hydro** Automatic Switchover can be used with either one remote meter or with two or more remote meters. Use of this switchover module is a great time saver and is a great aid in assuring a more constant supply of chlorine. Once installed, the **Hydro** Automatic Switchover is completely automatic and needs no adjustment or setting.



600 Emlen Way, Telford, PA 18969 • Telephone: (215) 799-0980 • Fax: (215) 799-0984  
Toll Free in the U.S.: 1 (888) 38-HYDRO • www.hydroinstruments.com • sales@hydroinstruments.com

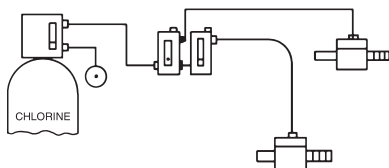

### Hydro Model 501-2 Multi-Point Application

**Hydro** chlorinator mounted on a single cylinder feeding two remote meters for two points of injection using two ejectors. Each meter and ejector operates independently. Chlorine capacity to 100 PPD (2000 grams/hr).

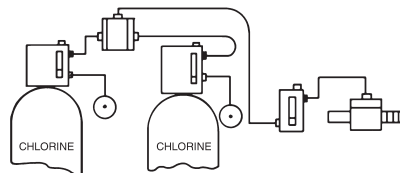

### Hydro Model 502 Automatic Stand-By

**Hydro** chlorinators – two chlorinators mounted on two cylinders with switchover module feeding one remote meter with rate valve feeding a single ejector. Capacity to 100 PPD (2000 grams/hr).

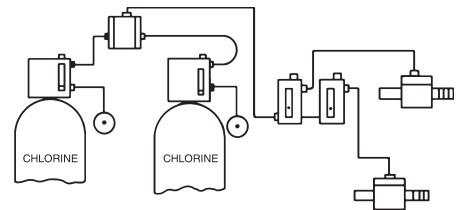

### Hydro Model 502-2 Automatic Stand-By with Multi-Point Feeding

**Hydro** chlorinators – two chlorinators mounted on two cylinders with switchover module feeding two or more remote meters with rate valves supplying two ejectors. Capacity to 100 PPD (2000 grams/hr) maximum.



# Series 500 GAS CHLORINATORS

The installation of **Hydro Gas Chlorinators** is easily accomplished. The following will be useful information.

## System Operating Temperatures

For best operation and safety, the chlorinator and cylinders should be protected from the elements and from direct sunlight.

## CHLORINE WITHDRAWAL RATE from 150 Pound (68 kg) Cylinder

Maximum Chlorinator Withdrawal Capacity		Minimum Ambient Temperature	
PPD	gr/hr	°F	°C
100	2000	40	4
50	1000	16	-9
25	500	0	-18
10	200	-6	-21
4	75	-20	-29

## Methods of Control

### Manual

Adjustment of rate valve and start/stop of water to ejector.

### Semi-Automatic

- Shutting off booster pump to ejector.
- Using solenoid valve to close vacuum line to ejector.

**Step-Feed** to multiple flow meters is available using solenoid valves in the vacuum line or water line to the ejector.

## Ejector Installation

1. Ejector connections must be kept above freezing temperatures.
2. At point of application maximum back pressure for standard ejector is 100 psig. (High pressure ejectors are available.)
3. Long solution lines from ejector should be avoided and if not, solution lines must be of adequate ID to reduce friction loss.
4. To create a vacuum the water supply to the ejector inlet must be higher than the pressure at the point of application (approximately 40 psig differential).
5. Maximum ejector operating temperature is 110° F (43° C).
6. Ejector may be wall mounted for remote applications.

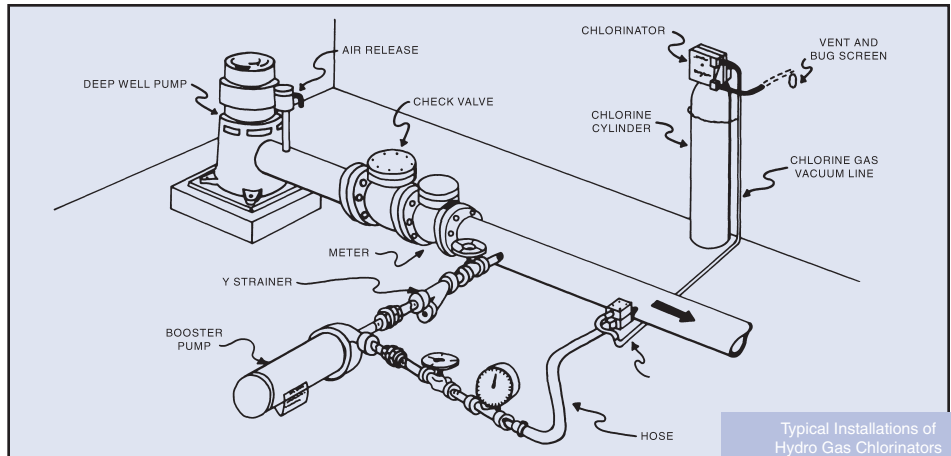

Typical Installations of Hydro Gas Chlorinators

Above: Deep Well Installation  
Below: Remote Controls Installation with Dual Cylinder Hook-Up

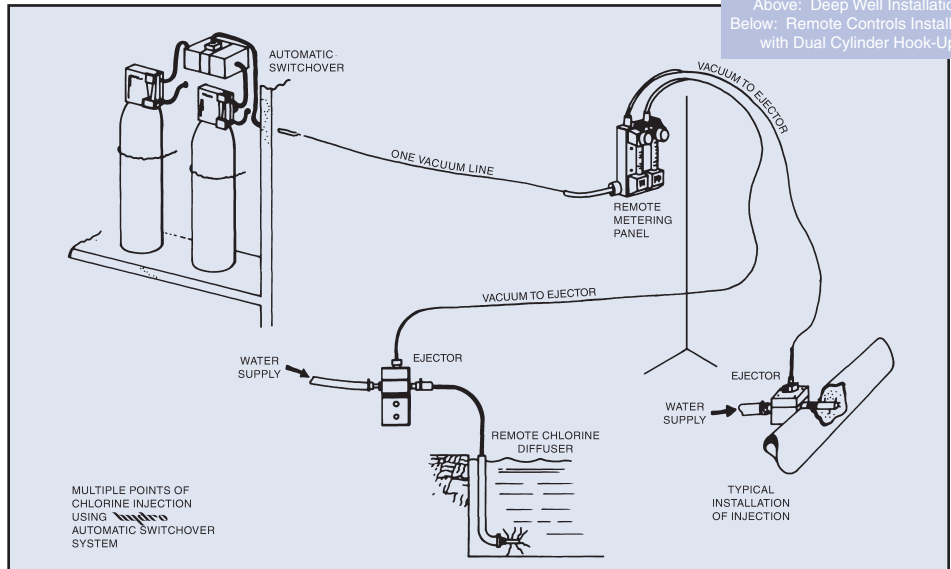

## Hydro Model EJ-1000 (up to 100 PPD)

	Standard	Options
Ejector Water Inlet (Nozzle)	UN-101 Universal Nozzle for both 1" (25.4 mm) ID hose and 3/4" (19 mm) NPT	None
Ejector Water Outlet (Diffuser)	E-1063 threaded diffuser for 3/4" (19 mm) NPT	<ul style="list-style-type: none"> <li>• E-1062 hose diffuser for 1" ID hose</li> <li>• E-109 3' long spray diffuser for 3/4" NPT</li> <li>• E-110 3' long open diffuser for 3/4" NPT</li> <li>• E-112 Universal Remote Diffuser for 1" ID hose or 3/4" NPT</li> </ul>

## Standard Tubing Connections Vacuum and vent tubing

Feed Rate		Vacuum Tubing Size	
PPD	gr/hr	Length of Tubing	
		100 ft. (30 m)	200 ft. (60 m)
50	1000	3/8" (9.52 mm) OD	3/8" (9.52 mm) OD
100	2000	3/8" (9.52 mm) OD	1/2" (12.7 mm) OD

Represented by



INSTRUMENTS

