

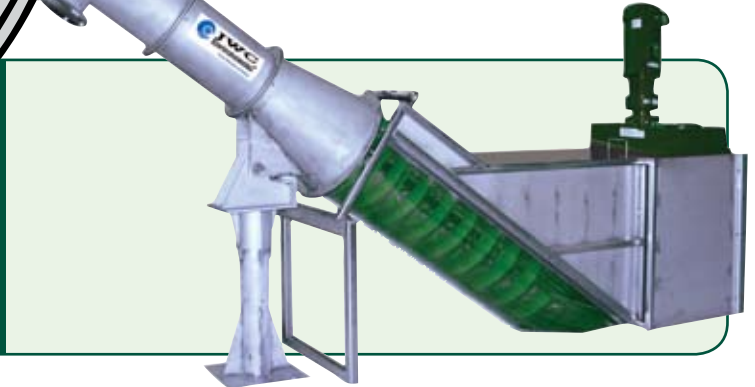

The
Screen
That Does
It All!

Auger Monster®

Complete Fine Screen System



Overview

The Auger Monster is a robust and affordable wastewater screen which combines three of JWCI's finest technologies – grinder, fine screen and compactor. It removes unwanted solids to make the treatment plant run more efficiently and make life easier for operators and managers.

Auger Monster combines five systems into one compact footprint. First, a powerful Muffin Monster® or Channel Monster® grinds all the incoming solids. Next, the ground solids are captured by a perforated plate screen and removed by a rotating auger. As solids are removed, dual wash water zones clean-off faecal material. The auger then conveys solids to the discharge point where the dewatering segment (optional) further increases dry solids content prior to discharge.

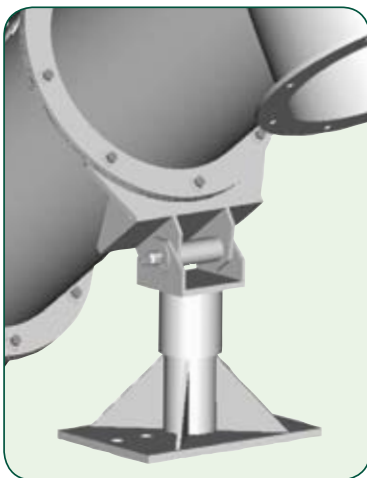

Auger pivots and swivels out of the channel—a JWCI Exclusive!

The cleaner, more compact discharge keeps odours to a minimum and reduces disposal costs, since less water and faecal material are sent to the landfill.

With the Auger Monster, wastewater screening couldn't get any easier—it's the screen that does it all!

Features & Benefits

Dual Shafted Grinder

- Proven Muffin Monster grinding technology
- Shreds long, stringy material to prevent wrapping
- Breaks-up clumps for more efficient washing

Spiral Lifting Screw

- Solids are removed while soft organics are washed back into the channel through a perforated screen
- Various screen sizes: 2, 3 or 6mm perforations

Cleaner Screenings Discharge

- Integrated spray wash cleans screenings and removes faecal material for cleaner discharge and reduced odours

Complete Fine Screen System

- Integrates high-flow grinding, screening, washing and dewatering technology
- Placement in existing channel with little or no civil work
- Simple to install

Easy Access, Pivoted Auger

- The auger is mounted to a fixed pivot point for easy servicing or removal
- Operators can simply bring the screening trough, auger brush and conveyor to deck level for inspection

Automated PLC Monitoring and Controls

- Auto load sensing and reversing protects the system
- Adjustable, differential auger cycle times for optimal solids removal and operating life
- Auger "fail-safe" mode ensures system continues running even if electronics are disabled



Trust Monster Quality™

www.jwci.co.uk



Operation

- 1) Unwanted solids suspended in the flow enter the Channel Monster section.
- 2) Solids are captured on the rotating drums (if included) and moved into the central grinder for size reduction. Even small solids, such as paper and cotton products, are captured and macerated.
- 3) Ground solids enter the perforated screening zone and are lifted out by the inclined auger. Wash water sprays clean the solids and remove soft organics, flushing them back into the flow.
- 4) Washed screenings are conveyed to deck level, then dewatered (optional), and deposited into a container or a bagging system (optional).

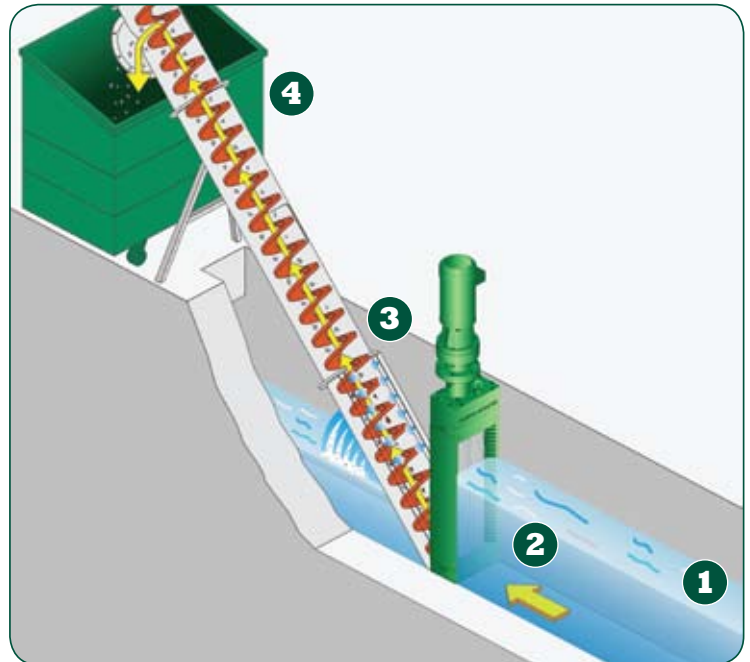

Cleaner, More Compact Discharge



Auger Monster discharge is cleaner, drier and more compact. The Auger Monster has become a favorite among wastewater operators and managers since it makes the inlet works cleaner, less time consuming and less expensive to operate.



Replaceable auger brush keeps perforated screen clean and helps transport solids.

Materials of Construction

Channel Frame: stainless steel

Cutters and Spacers: heat treated alloy steel, surface ground for uniformity and through-hardened to a minimum 45-50 Rockwell "C"

Shafts: heat treated hexagonal steel

End Housings and Covers: Ductile Iron

Seal Faces: Tungsten Carbide / Tungsten Carbide

Elastomers: Buna-N®

Auger System: stainless steel casings with alloy steel screw



Auger Monster®

Model ALE • Auger - No Grinder

1.5 kW IP55 TEFC auger motor (immersible IP68 and other standards optional). Minimum channel depth from 660mm and up - based on frame height. Shown with optional Screenings Washer Monster®.

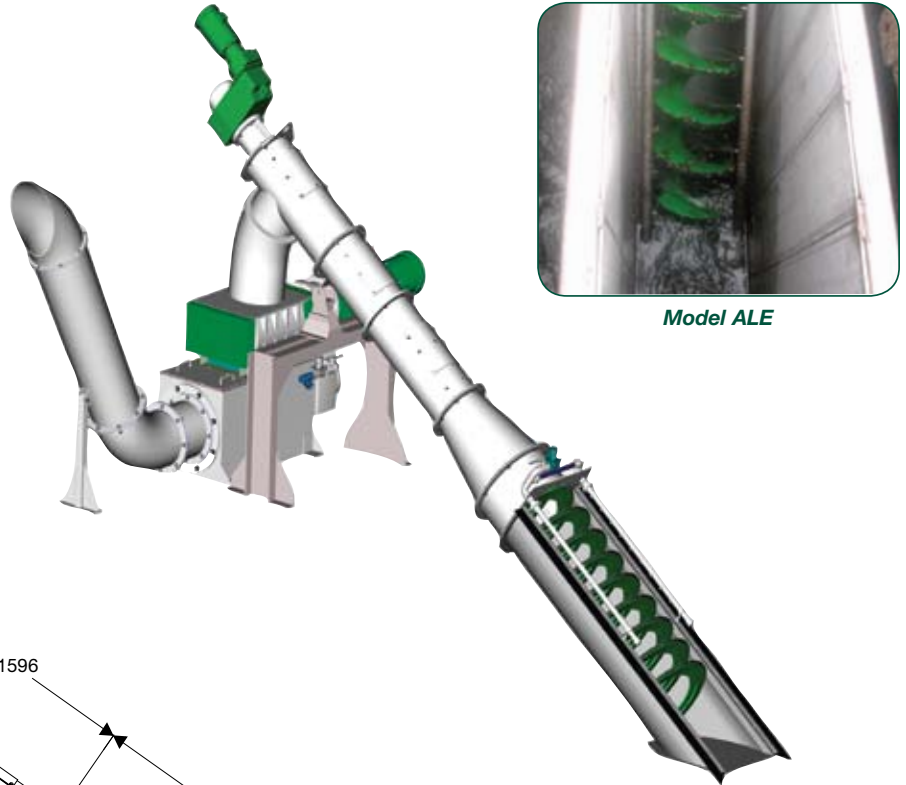

Model ALE

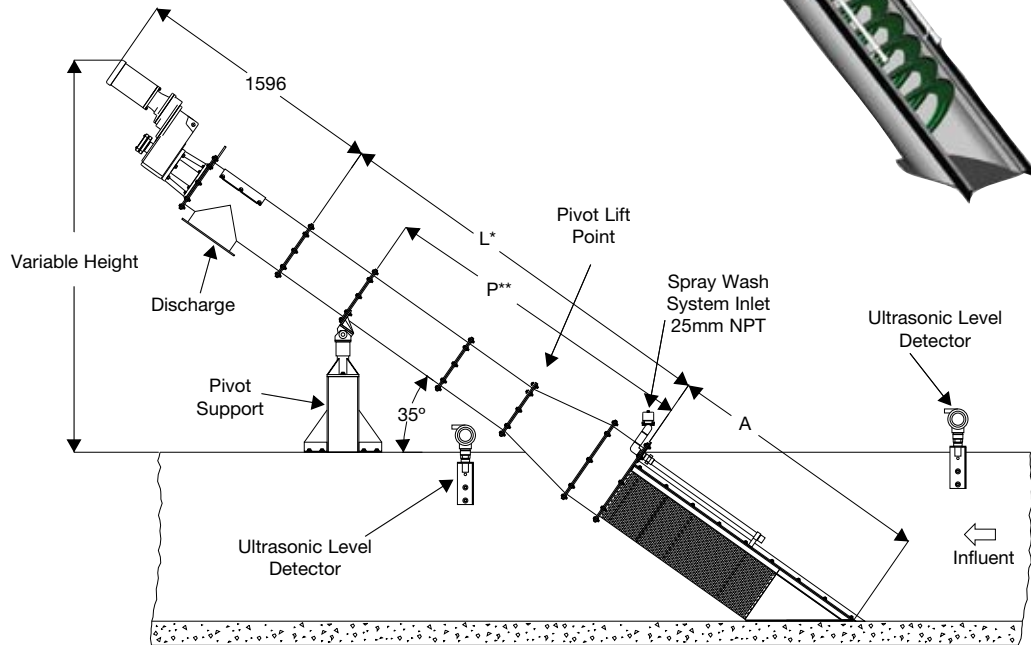
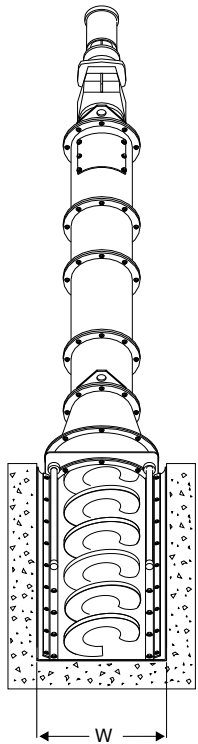

Model	A mm	W - Min. Channel Width - mm	Flow Capacity m ³ /h
ALE1800-480	1716	610	542
ALE2400-480	2086	610	694
ALE3200-480	2456	610	902
ALE4000-480	2825	610	1107
ALE5000-480	3192	610	1370
ALE6000-480	3556	610	1646

Measurements based on 480mm unit. 170mm and 285mm options also available

*L Transport Lengths	Variable transport lengths from 2,000 to 4,000 mm in 250 mm increments. Consult factory for configuration assistance.
**P Pivot Location	Variable pivot locations from 2,000 to 3,000 mm in 250mm increments. Consult factory for configuration assistance.

Measurements apply to ALE, ACE and AGE models.



Auger Monster captures, washes and conveys.



Auger Monster®

Model ACE • Single Drum

1.5 kW IP55 TEFC auger motor (immersible IP68 and other standards optional). 4 kW grinder motor. 0.75 kW drum motor. Minimum channel depth from 660mm and up - based on frame height. 480mm unit shown. 170mm and 285mm options also available. Flow based on optimum channel conditions. Please consult factory for final analysis of application and flow rate.

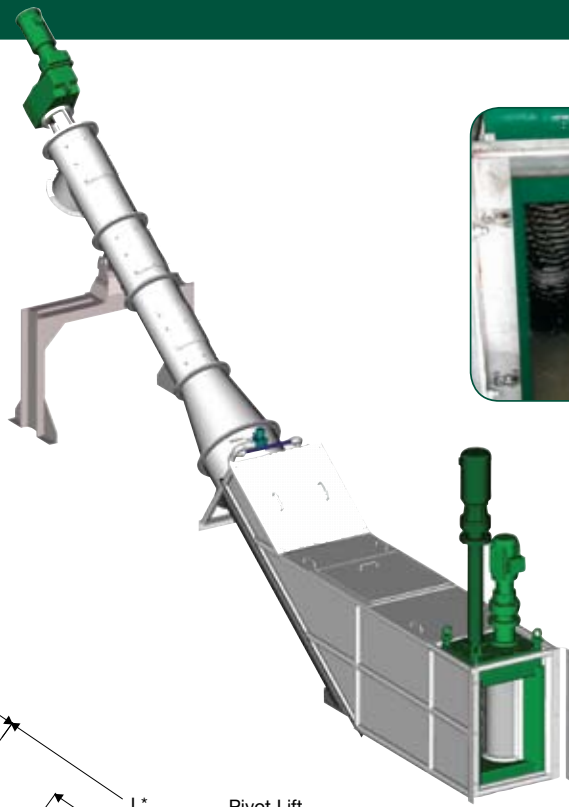

Model ACE

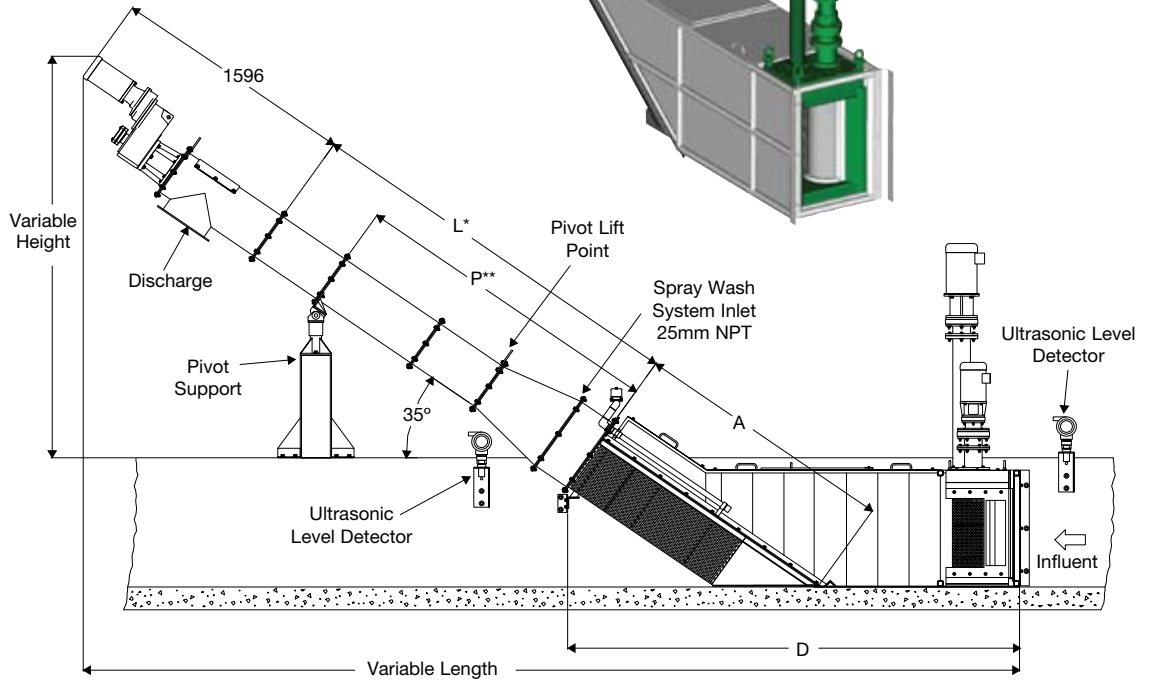
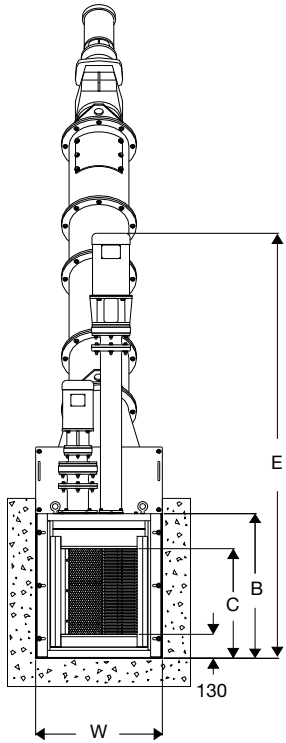

Model	A mm	B mm	C mm	D mm	E mm	W Min. Channel Width - mm	Flow Capacity m ³ /h
ACE1810-480	1716	781	592	2935	2254	762	342
ACE2410-480	2086	924	738	3340	2397	762	465
ACE3210-480	2456	1124	938	3666	2597	762	636
ACE4010-480	2825	1321	1135	4042	2794	762	807
ACE5010-480	3192	1576	1389	4408	3050	762	1029
ACE6010-480	3556	1840	1653	4763	3313	762	1261

With stainless steel frame as shown. 610mm minimum channel width available using grinder-only frame.



Auger Monster discharge.



Auger Monster and a cross conveyor.



Auger Monster in the UK.



Auger Monster®

Model AGE • Grinder and Screen

1.5 kW IP55 TEFC auger motor (immersible IP68 and other standards optional). 4 kw grinder motor. Minimum channel depth from 660mm and up - based on frame height. 285mm unit shown. 170mm and 480mm options also available. Flow based on optimum channel conditions. Please consult factory for final analysis of application and flow rate.

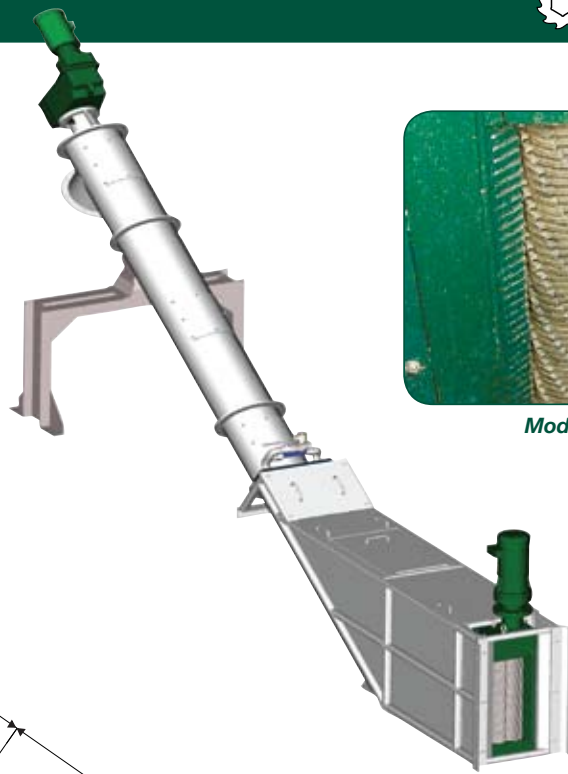

Model AGE

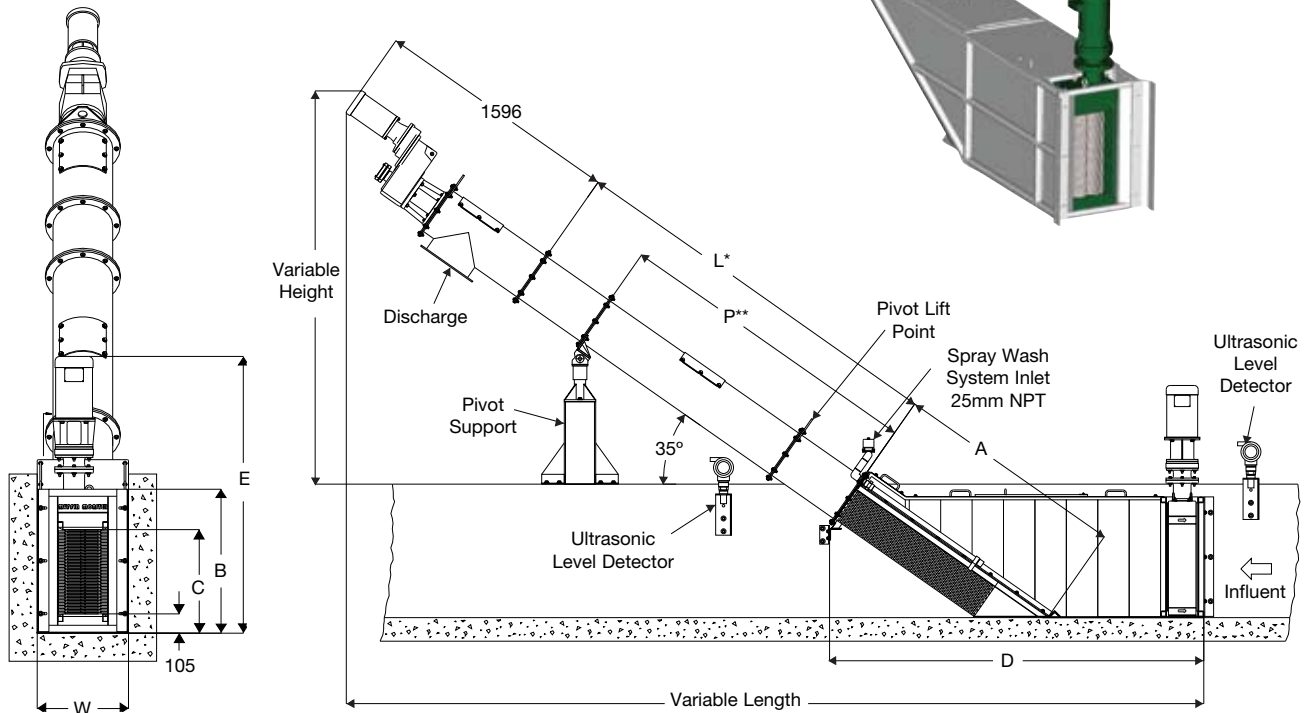

Model	A mm	B mm	C mm	D mm	E mm	W Min. Channel Width* - mm	Flow Capacity m ³ /h
AGE1800-285	1497	781	562	2421	1502	558	168
AGE2400-285	1867	924	714	2772	1648	558	223
AGE3200-285	2242	1124	918	3169	1845	558	298
AGE4000-285	2611	1321	1121	3546	2048	558	382
AGE5000-285	2981	1576	1375	3910	2302	558	505
AGE6000-285	3346	1840	1629	4267	2565	558	642

* With stainless steel frame as shown. 406mm minimum channel width available using grinder-only frame and 285mm auger. 305mm minimum channel width available using grinder-only frame and 170mm auger.



Discharging into a bag.



Auger Monster in Scotland.



Sludge screening application.

Auger Monster Options

Screen Sizes

- 2, 3 or 6 mm perforated screens
- Fits channels 305mm and up with 170mm auger

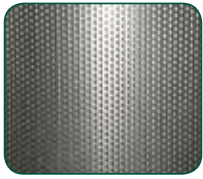

2mm

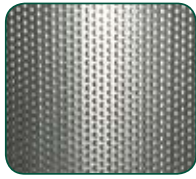

3mm

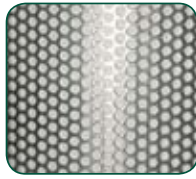

6mm

Conveyor Options

- Convey discharged solids vertically, horizontally or at an angle.
- Sluice conveyor

Additional dewatering

- Dewatering section at the end of the auger compresses material to save on transport and disposal fees



Conveyor

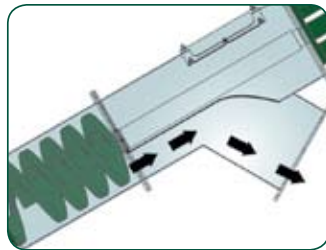

Compaction zone

Dual Shafted Grinder

- Various cutter stack heights to fit your channel and flow requirements
- Multiple cutter options
- High-flow side rails
- Channel Monster® with high-flow screening drum



30000 Grinder Option



40000 Grinder Option



Channel Monster Option



Electric motor



Blanket



Bagger

Motors

- Single or Multi-drive
- Electric motor: 4, 7.5 kW
- Explosion proof electric motor: 4, 7.5 kW
- IP68 Motor: 2.2, 4, 7.5 kW

Extended Motor Shaft

- Drive shaft extension puts motor above the highest overflow level. Available in 150mm increments. Maximum 3600mm.

Overflow Bar Screens

- Stainless steel bars attached to frame prevent solids from passing during an overflow event.

High-tech Controllers

- Enclosure options: standard; explosion proof; weather proof IP65
- Dual motor option allows independent operation of the cutter stack and drum

Discharge Bagger

- Screenings can be collected inside a plastic bag affixed to the end of the discharge chute
- Operator simply pulls the trash bag from the ring and ties it off

Cold Weather System

- Heat tracing and insulation blanket prevent freezing
- High performance is assured in colder climates
- Operates outdoors, no need for a building or covering



Extended shaft



Controller



Unit 15, Daneside Business Park
River Dane Road
Congleton, Cheshire CW12 1UN
United Kingdom
Phone: +44 1260 277047
Fax: +44 1260 277557
jwci@jwce.com



www.jwci.co.uk